

RAISE YOUR GAME
HYVA PERFORMANCE



THE PERFECT SOLUTION
FOR APPLICATIONS
ON ALL VEHICLES





We Move your World

From light, compact machines, to solutions which deliver the ultimate levels of precision and lifting capacity, Hyva truck-mounted cranes are all built on the foundations of high performance, reliability, ease of use and safety. That's why they're among the most widely-used loader cranes in the world.

KENNIS ROLLOADER CRANES

Allowing the operator to cover a wide area with a limited number of extensions, Kennis cranes offer a number of significant advantages, including shorter loading and unloading times, high proximity to the load and high payloads. The crane can easily be removed from the trailer and installed on another. The rollover cranes from Kennis (cranes by Hyva) are renowned for their reliability and durability.

Hyva: Your Trusted Partner.



Hyva Worldwide

Founded in 1979, Hyva is today one of the world's leading providers of innovative and highly efficient transport solutions for the commercial vehicle and environmental service industries. With over 30,000 customers and more than 40% of the global front-end tipping cylinders segment for heavy duty trucks, the company operates in more than 110 countries, has more than 30 fully owned subsidiaries, and a manufacturing base that includes 14 production facilities across China, India, Brazil and Europe. We are committed to the development, production, marketing and distribution of solutions for the movement and transportation of goods.

The growth and success of Hyva is built on two key aspects of its operation: the quality and innovative nature of the company's solutions, and the excellence of its customer support. The first of these, product quality, is illustrated by the fact that Hyva today offers the strongest front-end hydraulic





telescopic cylinder in the world, as well as a full range of double acting cylinders, fixed mounted and rolling truck cranes, container lifting systems (hookloaders and skiploaders) and waste collection units. They are solutions which are used worldwide across a range of sectors including transport, construction, mining, materials handling and environmental services providers.

Service quality, too, is a fundamental part of the Hyva business philosophy: with operations in more than 110 countries, the company operates one of the world's most extensive customer support networks in the industry. It is a network which has earned Hyva an international reputation for excellence in customer care.





Full range of applications with Hyva Cranes



Building



Construction



Oil&Gas



Mining



Rental



Logistic



Gardening



Power
station



Maintenance



Waste
handling

Raise your game with our complete line of cranes

HA

From 1 to 11 tm class
Compact telescopic cranes

Page 24 to page 37

HT

From 9 to 24 tm class
Telescopic cranes:
easy to use

Page 38 to page 45

HB

From 3 to 70 tm class
User-friendly articulated cranes

Page 46 to page 79

HB-R

From 33 to 66 tm class
Large, user-friendly articulated cranes

Page 80 to page 87

HC

From 9 to 165 tm class
Best in class articulated cranes

Page 88 to page 161

HV

From 3 to 22 tm class
Cost and Performance perfect solutions

Page 162 to page 171

MAN BASKET

From 5 to 7 tm class

Page 172 to page 175

FFB

From 1 to 5 tm class
Specialized cranes for agricultural tractors

Page 176 to page 181

HZ

From 4 to 27 tm class
Specialized cranes for timber and recycling

Page 182 to page 203

KENNIS CRANES BY HYVA

From 13 to 40 tm class
Applications rollover cranes

Page 204 to page 213



Environmental protection

As part of our corporate responsibility Hyva is dedicated to protect the environment.

Painting filter

The air in and around the painting area is passed through a series of filters to remove the harmful chemicals from the air. Air quality is checked regularly to confirm correct operation of the system.

Heating system

Large spaces are more efficiently heated from below, rather than from above. In-floor heating is installed in most of our production area to make the most efficient use of energy.

ISO14001 Certification

Hyva is a certified ISO 9001 and ISO 14001 company by Lloyd's Register Quality Assurance (LRQA): the world's leading provider of independent assessment services including certification, validation, verification and training across a broad spectrum of standards and schemes, with recognition from over 50 accreditation bodies.



Certificate of Approval

This is to certify that the Management System of:
H.C.E. S.r.l. Unico Socio
 Via Einstein, 4/6, 42026 Poviglio, Italy

has been approved by LRQA to the following standards:
 ISO 9001:2015



P.G. Cornelissen - Area Manager North Europe
 Issued By: Lloyd's Register Nederland B.V.
 for and on behalf of: Lloyd's Register Quality Assurance Limited

This certificate forms part of the approval identified by approval number: 0023911

Current Issue Date: 1 November 2018	Original Approvals:
Expiry Date: 31 October 2021	ISO 9001 – 15 May 1991
Certificate Identity Number: 10093487	

Approval Number(s): ISO 9001 – 0023911-009

The scope of this approval is applicable to:
 Design, manufacture and service of hydraulic powered loader cranes for trucks
 and marine applications. Manufacture and service of hook loader and roller crane.

 001

Lloyd's Register Group Limited, its affiliates and subsidiaries, including Lloyd's Register Quality Assurance Limited (LRQA), and their respective officers, employees or agents, are not liable to the extent of this document or any part thereof for any loss, damage or expense caused by reliance on the information or advice in this document or for any other reason, unless the person has agreed in writing with the relevant Lloyd's Register entity for the provision of the information or advice and that other any responsibility or liability is not excluded or limited. Lloyd's Register Quality Assurance Limited, 1 Trinity Park, Boulevard Lane, Borehamwood B95 7TB, United Kingdom.

Page 1 of 1

Preserving the earth for future generations

ISO14001 certification achieved by the factory in Poviglio (Italy) allowed Hyva to contribute to protect and preserve the environment in which we live.

In the last five years we have saved 212* tons of paper and preserved 3,180 trees. We have recycled 200* tons of wood. We saved 93,280,000* litres of drinking water. We recycled 58* tons of plastic saving 193* tons of oil.

In the last five years we saved 1,611,200* kwh and we recovered 183* tons of iron. We reduced CO2 emission in the air by 25%*.

* Certified source



From concept to field

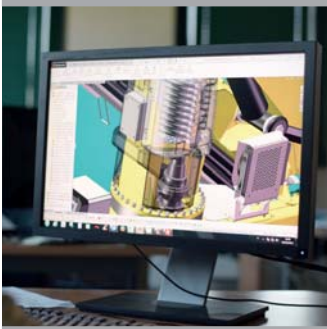

Crane Design

Our research and development department uses the latest technology to design new products.

Each individual component of the crane is designed using a 3D CAD system which can test crane movements and ensure that it has a functional geometry.

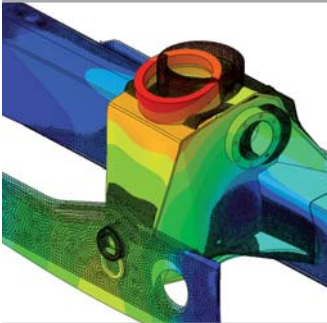

Structural verifications

During the design phase, FEM (Finite Element Method) is used to analyse the crane structure and loading conditions and obtain strength-to-weight optimisation.



Prototype development

Each component is checked for conformity to specification and assembled in a dedicated and specially equipped prototyping area.

And, every step is documented, with photographs, for precise tuning of the assembly process once it goes into production.



Tested in all conditions

Once assembled, every aspect of the prototype is fatigue tested.

Every operating parameter is monitored by computer to detect any anomalies. Each prototype is subjected to up to 600,000 cycles of loading, to simulate 10 years of normal crane operations.



Field test

New cranes are delivered to expert users to be used in real, day-to-day operating conditions, including heavy duty applications.

Direct communication between the user and R&D allows feedback for improvements.

Cranes are launched only after a complete field testing programme.



Stability control systems (CE)

HS System

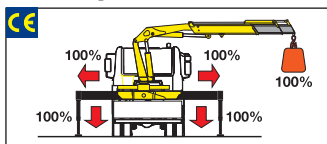

The **HS System** integrated in the load limiting device checks the stabilizers' positions. Only when all beams are fully open and all stabilizers are on the ground the crane can operate and lift loads.



Control display

HM System

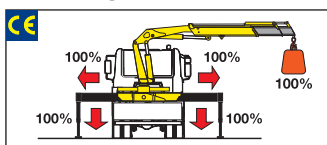

The **HM System** integrated in the load limiting device checks the stabilizers' positions. Only when all beams are fully open and all stabilizers are on the ground the crane can operate and lift loads.



Control display

HML System

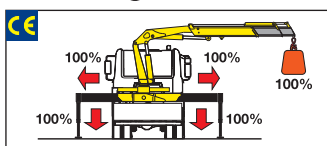

The **HML System** integrated in the load limiting device checks the stabilizers' positions. Only when all beams are fully open and all stabilizers are on the ground the crane can operate and lift loads.



HL System

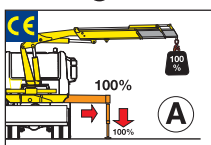

The **HL system** checks the stabilizers' positions and the truck's inclination.

According to the beams' positions, the system allows two operating modes:

Mode A - all beams fully open and all stabilizers feet on the ground.

Mode B - stabilizers on the ground only.

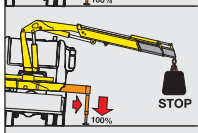
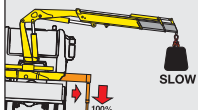
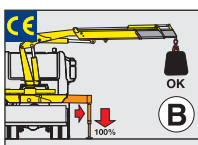

In **mode A**: the load limiting device stops the crane when the crane reaches 100% of the nominal capacity.

In **mode B**: a dedicated sensor monitors the truck's inclination. The load limiting device stops the crane before it reaches an inclination angle dangerous for stability, or when the crane reaches its nominal capacity.



Control display



HXL System

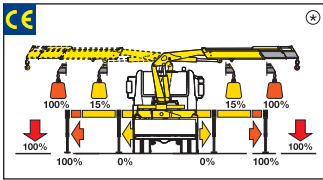

The **TCU** checks the positions of the stabilizers beams, monitoring for two possible positions: beam fully open, beam not fully open.

Depending on the position of the beams and the stabilizers, the crane's lifting capacity changes according to the setting made by the installer. This allows the operator to use the crane even with a beam partially or fully retracted without having stability problems.

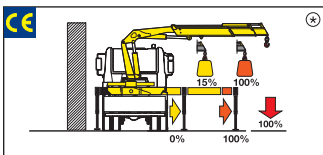

Optional HRCS

The Rotation Control Sensor constantly checks the slewing position of the crane and limits the lifting capacity depending on the beams' and the stabilizers positions.

⊛ The percentages present in the pictures are merely examples and they have no bearing on the cranes' real lifting capacities. The cranes' real lifting capacities will depend on truck's stability.

H2XL System

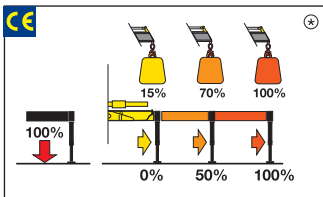

The **TCU** checks the positions of the stabilizers and divides the working area into 4 slewing sectors: over the cabin, right side, left side and the rear of the vehicle.

Depending on the position of the beams and the stabilizers, the crane's lifting capacity changes according to the settings made by the installer. This allows the operator to use the crane even with a beam partially or fully retracted without having stability problems.



HPES The **HPES** (Proportional Encoder Sensor) recognizes 3 positions of the stabilizers' beams: fully open, half extended, fully closed.

HRCS The **HRCS** (Rotation Control Sensor) recognizes 4 slewing sectors: over the cabin, right side, left side, to the rear of the vehicle.

The **CAN-BUS** radio-control allows the operator to know the positions of the stabilizers and the loading conditions of the crane.

With manual opening stabilizers, the **H2XL System** only recognizes completely open or completely closed beam positions.



⊛ The percentages present in the pictures are merely examples and they have no bearing on the cranes' real lifting capacities. The cranes' real lifting capacities will depend on truck's stability.

Stability control systems (CE)

H2XL+ System

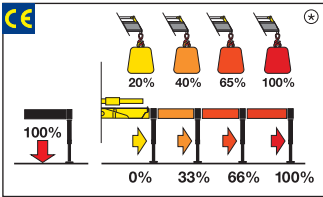

The TCU detects the positions of the stabilizers and divides the working area in 8 slewing sectors: 2 over the cabin, 2 on right side, 2 on left side and 2 to rear of the vehicle. Depending on the stabilizers spreads, the crane's lifting capacity changes according to the parameters set by the installer. This allows the operator to use the crane even with stabilizers partially or fully retracted always ensuring stability and safety.

 The HPES (Proportional Encoder Sensor) recognizes 4 positions of the stabilizers' beams: fully extended, 2/3 extended, 1/3 extended and fully retracted.

 The HRCS (Rotation Control Sensor) recognizes 8 slewing sectors: 2 over the cabin, 2 on right side, 2 on left side, 2 to rear of the vehicle.

⊛ The percentages present in the pictures are merely examples and they have no bearing on the cranes' real lifting capacities. The cranes' real lifting capacities will depend on truck's stability.

H3XL System

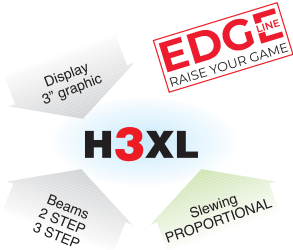
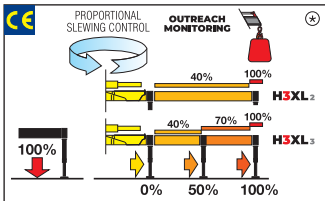

With a 3" TFT display and ergonomic keyboards, the operator can supervise the crane working and select the best parameters for effective use. The H3XL system controls proportional slewing and the crane's stability, with 2-steps (H3XL₂) or 3-steps (H3XL₃) stabilizers outreach monitoring, depending by crane model and configuration.

⊛ The percentages present in the pictures are merely examples and they have no bearing on the cranes' real lifting capacities. The cranes' real lifting capacities will depend on truck's stability.

H4XL+TOP System

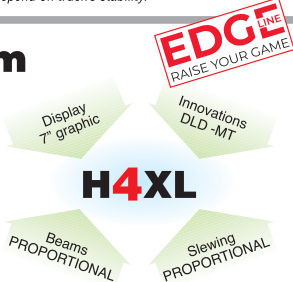
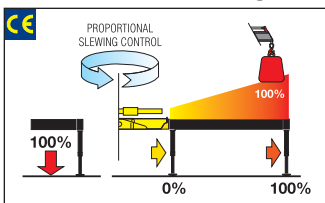

A 7" colour display with integrated keyboard gives the operator a higher level of awareness of the crane operation and allows selection of the best parameters for effective use. The system detects the exact position of the beams and proportionally calculates the stability.

Technical features

EES Extra Extension Speed

A special regenerative valve re-uses oil during extension, ensuring an incredibly high speed without compromising the safe operation of the crane.

Extensions speed comparison

Model	2S	3S	4S	5S
Standard	22"	32"	42"	51"
EES	10"	16"	22"	29"

SDS Smooth Descent System

This system compensates for boom oscillation, ensuring smooth movement of the load.

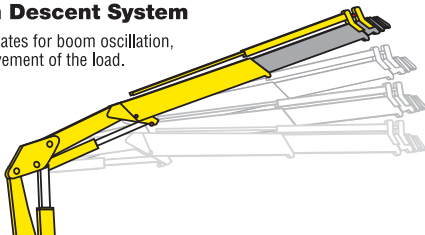

TCU Total Control Unit

TCU is a monitoring system designed by Hyva Crane to control all aspects of crane operation, including control of accessories. A display shows the user the state of the crane and easy on-board diagnostics allow the technician and dealer to inspect the activities of the crane.



LCS Lift Control System

Lift Control System increases the capacity of the crane up to 10% by reducing the speed when the crane is near its maximum lifting capacity.

P-LCS Proportional Lift Control System

The proportional system increase the capacity up to 15% by a proportional speed reduction when the crane is near to the maximum lifting capacity.

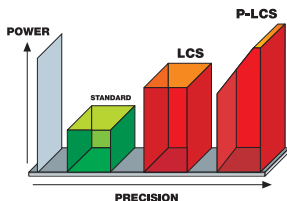

LAS Liftrod Articulating System

Thanks to the connecting rods the lifting capacity of the crane is constant in all boom positions.

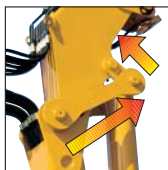

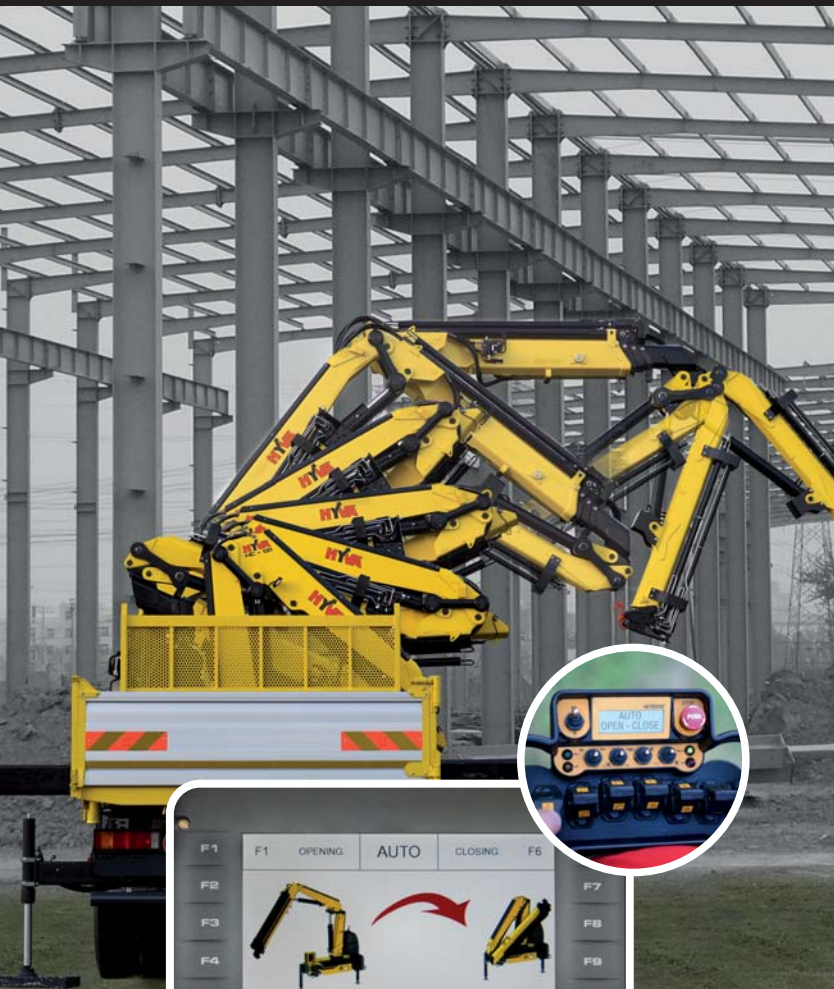

Magic Touch



Focus on innovation

A graphic display which allows the driver, after truck stabilisation, to automatically fold (from any position to transport position) and unfold (to working position) when required. This easy-to-use function improves driver attention, promotes safe operation, saves time and can increase productivity.



DLD Dynamic Load Diagram

Focus on innovation

A new system which allows the driver to verify in advance the crane lifting capacity based on the truck stability. The operator can select the weight and, according to the stabiliser positions, the system calculates the stability all around the truck. A graphical display shows the outreach available for the load selected and the actual boom slewing position. This system, a first on truck-mounted articulated cranes, optimises stabilisation and makes crane operation safer and more efficient. Easy to use, saves time and improves safety through better crane stabilisation and avoidance of border line working conditions.

Radio Remote Controls

Single hand proportional system
The power in your hands



■ **Safety**
Stabilizer control by radio

■ **Functionality**
Proportional speed control of any single movement



Proportional speed control

■ **Comfort**
Single-handed control of every crane function

■ **Ergonomic**
Compact dimensions and reduced weight



Batteries type AA standard



Pressure compensated inlet section: BOSCH

Multifunction radio controls



A wide range of radio control can be chosen: Scanreco, Hetronic and Autec



Hetronic Not CE



Scanreco



CAN-Bus

Hetronic CE Basic



Autec
(only for HC 1651)

EDGE LINE
RAISE YOUR GAME



Hetronic CE Graphic



4" TFT HD color display to keep the crane always under control

Operator can control the crane with high precision and fully supervise the loading and unloading operations.

■ Multifunction remote control

■ Protected against radio interference

■ Move around the truck freely



Pressure compensated control valve: HAWE PLS2



Pressure compensated control valve: SAUER DANFOSS PVG32



EDGE LINE RAISE YOUR GAME

NEW EDGE line cranes from Hyva, cutting edge innovation for 1st class lifting experience.

A new control station, incorporating both crane and stabiliser controls, has an ergonomic working position and user-friendly interface which delivers better operator efficiency and safety together with improved productivity.

Dynamic Load Diagram allows advance verification of the crane lifting capacity based on the truck stability, and, Magic Touch allows automatic folding and unfolding to transport and working positions.

There are several options for radio remote control and a wide range of stabiliser configurations to ensure safe positioning of the truck in all ground conditions.



The wide slewing angle, 425°, is best-in-class for medium sized cranes. And, with an extensive range of accessories and attachments, the cranes are suited to a wide range of applications.

Durability and lifetime value too is high with enhanced resistance to adverse environmental conditions as a result of a long life painting process, anti-corrosion treatments on non-painted components, protected rubber hose tracks and assembly of components using specialist tools.



HA

HA 10

HA 14

HA 15

HA 21

HA 22

HA 27

HA 28

HA 33

HA 50

HA 70

HA 100

HA 110

Line of telescopic cranes made to satisfy customers in need of a crane which is compact, light and easy to operate

HA 10

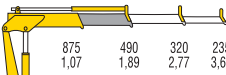
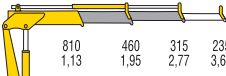

HA10 E1	
kg	875 490 320 235
m	1,07 1,89 2,77 3,65
HA10 E2	
kg	810 460 315 235
m	1,13 1,95 2,77 3,65

CE	<input checked="" type="checkbox"/>
NO CE	<input checked="" type="checkbox"/>
MANUAL	<input checked="" type="checkbox"/>
RADIO	<input checked="" type="checkbox"/>

MODELS	LIFTING MOMENT	MAX VERTICAL REACH (HYDR)	SLEWING ANGLE	SLEWING TIME	MAX WORKING HEEL	WORKING PRESSURE	CRANE WEIGHT WITHOUT STABILIZERS	OIL TANK CAPACITY	OIL FLOW	DIMENSIONS
	tm	m	°	s/180°	°	bar	kg	l	l/min	mm B x h x S
HA10 E1	0,94	3,01	328	16	3	180	145	17,5	5	595x1240x370
HA10 E2	-	3,85	328	16	3	180	175	17,5	5	647x1240x370

HA 14



HA14 E1					
kg		995	675	450	320
m		1,07	1,89	2,77	3,65

HA14 E2					
kg		995	635	440	320
m		1,13	1,95	2,77	3,65

CE	<input checked="" type="checkbox"/>
NO CE	<input type="checkbox"/>
MANUAL	<input checked="" type="checkbox"/>
RADIO	<input checked="" type="checkbox"/>

MODELS	LIFTING MOMENT	MAX VERTICAL REACH (HYDR)	SLEWING ANGLE	SLEWING TIME	MAX WORKING HEEL	WORKING PRESSURE	CRANE WEIGHT WITHOUT STABILIZERS	OIL TANK CAPACITY	OIL FLOW	DIMENSIONS
	tm	m	°	s/180°	°	bar	kg	l	l/min	mm B x h x S
HA14 E1	1,28	2,98	335	10	3	160	174	17,5	8	620x1241x430
HA14 E2	-	3,80	335	10	3	160	193	17,5	8	672x1241x430

HA 15



HA15 E1

kg	1195	675	450	320
m	1,07	1,89	2,77	3,65

HA15 E2

kg	1115	635	440	320
m	1,13	1,95	2,77	3,65

CE	<input checked="" type="checkbox"/>
NO CE	<input checked="" type="checkbox"/>
MANUAL	<input checked="" type="checkbox"/>
RADIO	<input checked="" type="checkbox"/>

MODELS	LIFTING MOMENT	MAX VERTICAL REACH (HYDR)	SLEWING ANGLE	SLEWING TIME	MAX WORKING HEEL	WORKING PRESSURE	CRANE WEIGHT WITHOUT STABILIZERS	OIL TANK CAPACITY	OIL FLOW	DIMENSIONS
	tm	m	°	s/180°	°	bar	kg	l	l/min	mm B x h x S
HA15 E1	1,28	2,98	335	10	3	160	174	17,5	8	620x1241x430
HA15 E2	-	3,80	335	10	3	160	199	17,5	8	672x1241x430

HA 21



HA21 E1										
kg	995	930	630	410						
m	1,23	2,15	3,16	4,12						
HA21 E2										
kg	995	880	620	410						
m	1,31	2,23	3,16	4,12						
HA21 E3										
kg	995	755	530	410	290					
m	1,38	2,31	3,23	4,16	5,11					

CE	<input checked="" type="checkbox"/>
NO CE	<input type="checkbox"/>
MANUAL	<input checked="" type="checkbox"/>
RADIO	<input checked="" type="checkbox"/>

MODELS	LIFTING MOMENT	MAX VERTICAL REACH (HYDR)	SLEWING ANGLE	SLEWING TIME	MAX WORKING HEEL	WORKING PRESSURE	CRANE WEIGHT WITHOUT STABILIZERS	OIL TANK CAPACITY	OIL FLOW	DIMENSIONS
	tm	m	°	s/180°	°	bar	kg	l	l/min	mm B x h x S
HA21 E1	2,00	3,56	335	10	3	160	216	17,5	8	695x1521x430
HA21 E2	-	4,51	335	10	3	160	240	17,5	8	710x1521x430
HA21 E3	-	5,45	335	10	3	150	262	17,5	8	868x1521x430

HA 22



Model	kg	kg	kg	kg	kg
HA22 E1	1610	930	630	410	
m	1,23	2,15	3,16	4,12	
HA22 E2	1505	880	620	410	
m	1,31	2,23	3,16	4,12	
HA22 E3	1285	755	530	410	290
m	1,38	2,31	3,23	4,16	5,11

CE	<input checked="" type="checkbox"/>
NO CE	<input checked="" type="checkbox"/>
MANUAL	<input checked="" type="checkbox"/>
RADIO	<input checked="" type="checkbox"/>

MODELS	LIFTING MOMENT	MAX VERTICAL REACH (HYDR)	SLEWING ANGLE	SLEWING TIME	MAX WORKING HEEL	WORKING PRESSURE	CRANE WEIGHT WITHOUT STABILIZERS	OIL TANK CAPACITY	OIL FLOW	DIMENSIONS
	tm	m	°	s/180°	°	bar	kg	l	l/min	mm B x h x S
HA22 E1	2,00	3,56	335	10	3	160	216	17,5	8	695x1521x430
HA22 E2	-	4,51	335	10	3	160	243	17,5	8	710x1521x430
HA22 E3	-	5,45	335	10	3	150	265	17,5	8	868x1521x430

HA 27



Model	kg	995	995	830	610	
HA27 E1	m	1,32	2,25	3,24	4,24	
HA27 E2	m	1,39	2,32	3,24	4,24	
HA27 E3	m	1,46	2,39	3,31	4,24	5,19

CE	<input checked="" type="checkbox"/>
NO CE	<input type="checkbox"/>
MANUAL	<input checked="" type="checkbox"/>
RADIO	<input checked="" type="checkbox"/>

MODELS	LIFTING MOMENT	MAX VERTICAL REACH (HYDR)	SLEWING ANGLE	SLEWING TIME	MAX WORKING HEEL	WORKING PRESSURE	CRANE WEIGHT WITHOUT STABILIZERS	OIL TANK CAPACITY	OIL FLOW	DIMENSIONS
	tm	m	°	s/180°	°	bar	kg	l	l/min	mm B x h x S
HA27 E1	2,75	3,58	335	16	3	160	263	17,5	10	730x1587x440
HA27 E2	-	4,49	335	16	3	160	295	17,5	10	753x1587x440
HA27 E3	-	5,39	335	16	3	160	321	17,5	10	753x1587x440

HA 28



Model	kg	1220	830	610	
HA28 E1	2085	1220	830	610	
m	1,32	2,25	3,24	4,24	
HA28 E2	1960	1160	820	610	
m	1,39	2,32	3,24	4,24	
HA28 E3	1855	1105	780	605	465
m	1,46	2,39	3,31	4,24	5,19

CE	<input checked="" type="checkbox"/>
NO CE	<input checked="" type="checkbox"/>
MANUAL	<input checked="" type="checkbox"/>
RADIO	<input checked="" type="checkbox"/>

MODELS	LIFTING MOMENT	MAX VERTICAL REACH (HYDR)	SLEWING ANGLE	SLEWING TIME	MAX WORKING HEEL	WORKING PRESSURE	CRANE WEIGHT WITHOUT STABILIZERS	OIL TANK CAPACITY	OIL FLOW	DIMENSIONS
	tm	m	°	s/180°	°	bar	kg	l	l/min	mm B x h x S
HA28 E1	2,75	3,58	335	16	3	160	263	17,5	10	730x1587x440
HA28 E2	-	4,49	335	16	3	160	298	17,5	10	753x1587x440
HA28 E3	-	5,39	335	16	3	160	323	17,5	10	753x1587x440

HA 33

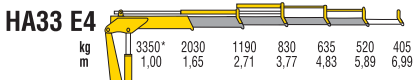
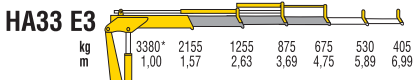
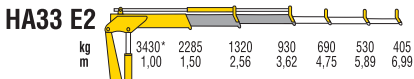
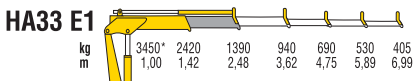

*) Theoretical lifting capacity

CE	<input checked="" type="checkbox"/>
NO CE	<input checked="" type="checkbox"/>
MANUAL	<input checked="" type="checkbox"/>
RADIO	<input checked="" type="checkbox"/>

MODELS	LIFTING MOMENT	MAX VERTICAL REACH (HYDR)	SLEWING ANGLE	SLEWING TIME	MAX WORKING HEEL	WORKING PRESSURE	CRANE WEIGHT WITHOUT STABILIZERS	OIL TANK CAPACITY	OIL FLOW	DIMENSIONS
	tm	m	°	s/180°	°	bar	kg	l	l/min	
HA33 E1	3,45	3,94	395	16	3	175	305	17,5	10	976x1702x440
HA33 E2	-	4,98	395	16	3	175	339	17,5	10	1040x1702x440
HA33 E3	-	6,01	395	16	3	175	371	17,5	10	1040x1702x440
HA33 E4	-	7,04	395	16	3	175	399	17,5	10	1040x1702x440

HA 50



HA50 E2

kg	3850*	2135	1205	835	585
m	1,00	1,80	3,15	4,52	5,98

HA50 E3

kg	3760*	1980	1125	770	585	425
m	1,00	1,90	3,25	4,62	5,98	7,45

HA50 E4

kg	3630*	1810	1035	705	525	425	320
m	1,00	2,00	3,35	4,72	6,08	7,45	8,90

*) Theoretical lifting capacity

CE	<input checked="" type="checkbox"/>
NO CE	<input checked="" type="checkbox"/>
MANUAL	<input checked="" type="checkbox"/>
RADIO	<input checked="" type="checkbox"/>

MODELS	LIFTING MOMENT	MAX VERTICAL REACH (HYDR)	SLEWING ANGLE	SLEWING TIME	MAX WORKING HEEL	WORKING PRESSURE	CRANE WEIGHT WITHOUT STABILIZERS	OIL TANK CAPACITY	OIL FLOW	DIMENSIONS
	tm	m	°	s/180°	°	bar	kg	l	l/min	mm B x h x S
HA50 E2	3,85	7,30	380	15	4	220	605	35	16	2085x1855x470
HA50 E3	-	8,80	380	15	4	220	650	35	16	2085x1855x470
HA50 E4	-	10,20	380	15	4	220	690	35	16	2085x1855x470

HA 70



HA70 E2

kg	6730*	3380	1885	1300	935	690
m	1,00	1,99	3,55	5,10	6,75	8,40

HA70 E3

kg	6620*	3225	1790	1230	935	690	470
m	1,00	2,05	3,62	5,20	6,75	8,40	10,00

HA70 E4

kg	6530*	3035	1700	1150	865	690	470
m	1,00	2,15	3,73	5,30	6,85	8,40	10,00

*) Theoretical lifting capacity

CE	<input checked="" type="checkbox"/>
NO CE	<input checked="" type="checkbox"/>
MANUAL	<input checked="" type="checkbox"/>
RADIO	<input checked="" type="checkbox"/>

MODELS	LIFTING MOMENT	MAX VERTICAL REACH (HYDR)	SLEWING ANGLE	SLEWING TIME	MAX WORKING HEEL	WORKING PRESSURE	CRANE WEIGHT WITHOUT STABILIZERS	OIL TANK CAPACITY	OIL FLOW	DIMENSIONS mm B x h x S
	tm	m	°	s/180°	°	bar	kg	l	l/min	
HA70 E2	6,73	7,80	387	15	4	260	780	35	18	2310x1995x550
HA70 E3	-	9,30	387	15	4	260	840	35	18	2310x1995x550
HA70 E4	-	10,9	387	15	4	260	900	35	18	2310x1995x550

HA 100



HA100 E1

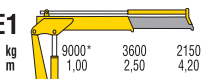

HA100 E2

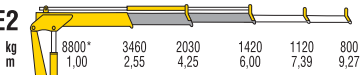

HA100 E3

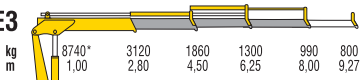

HA100 E4

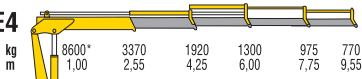

*) Theoretical lifting capacity

CE	<input type="checkbox"/>
NO CE	<input checked="" type="checkbox"/>
MANUAL	<input checked="" type="checkbox"/>
RADIO	<input checked="" type="checkbox"/>

Most recommended for car recovery trucks

MODELS	LIFTING MOMENT	MAX VERTICAL REACH (HYDR)	SLEWING ANGLE	SLEWING TIME	MAX WORKING HEEL	WORKING PRESSURE	CRANE WEIGHT WITHOUT STABILIZERS	OIL TANK CAPACITY	OIL FLOW	DIMENSIONS
	tm	m	°	s/180°	°	bar	kg	l	l/min	mm B x h x S
HA100 E1	9,00	7,60	395	17	4	260	900	60	20	2350x2300x625
HA100 E2	-	9,46	395	17	4	260	1000	60	20	2350x2300x625
HA100 E3	-	11,45	395	17	4	260	1080	60	20	2350x2300x625
HA100 E4	-	13,00	395	17	4	260	1145	60	20	2350x2300x625

HA 110



HA110 E2

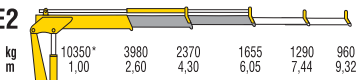

HA110 E3

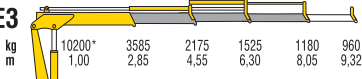

HA110 E4

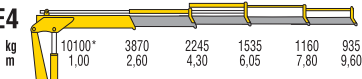

*) Theoretical lifting capacity

CE	<input type="checkbox"/>
NO CE	<input checked="" type="checkbox"/>
MANUAL	<input checked="" type="checkbox"/>
RADIO	<input checked="" type="checkbox"/>

Most recommended for car recovery trucks

MODELS	LIFTING MOMENT	MAX VERTICAL REACH (HYDR)	SLEWING ANGLE	SLEWING TIME	MAX WORKING HEEL	WORKING PRESSURE	CRANE WEIGHT WITHOUT STABILIZERS	OIL TANK CAPACITY	OIL FLOW	DIMENSIONS
	tm	m	°	s/180°	°	bar	kg	l	l/min	mm B x h x S
HA110 E2	10,3	9,46	395	17	4	295	1000	60	20	2350x2300x625
HA110 E3	-	11,45	395	17	4	295	1080	60	20	2350x2300x625
HA110 E4	-	13,00	395	17	4	295	1145	60	20	2350x2300x625



HT

HT 92

HT 112

HT 130

HT 162

HT 212

HT 240

Designed to be used in car recovery and in all other applications where a compact, light and easy to operate crane is needed

HT 92

SDS

HT92 E2

kg	8770*	4060	2150	1445
m	1,00	2,16	4,07	5,98

HT92 E3

kg	8740*	3900	2040	1375	990
m	1,00	2,24	4,15	6,05	8,00

HT92 E4

kg	8550*	3700	1940	1290	945	735
m	1,00	2,31	4,22	6,13	8,08	10,03

*) Theoretical lifting capacity

CE	<input checked="" type="checkbox"/>
NO CE	<input checked="" type="checkbox"/>
MANUAL	<input checked="" type="checkbox"/>
RADIO	<input checked="" type="checkbox"/>

MODELS	LIFTING MOMENT	MAX VERTICAL REACH (HYDR)	SLEWING ANGLE	SLEWING TIME	MAX WORKING HEEL	WORKING PRESSURE	CRANE WEIGHT WITHOUT STABILIZERS	OIL TANK CAPACITY	OIL FLOW	DIMENSIONS
	tm	m	°	s/180°	°	bar	kg	l	l/min	mm B x h x S
HT92 E2	8,77	9,2	425	20	4	310	945	75	40	2315x2295x825
HT92 E3	-	11,1	425	20	4	310	1040	75	40	2315x2295x825
HT92 E4	-	13,1	425	20	4	310	1115	75	40	2315x2295x825

HT 112

SDS

HT112 E2

kg	10250*	4745	2515	1705
m	1,00	2,16	4,07	5,98

HT112 E3

kg	10170*	4540	2395	1605	1205
m	1,00	2,24	4,15	6,05	8,00

HT112 E4

kg	10100*	4375	2300	1520	1125	900
m	1,00	2,31	4,22	6,13	8,08	10,03

*) Theoretical lifting capacity

CE	<input checked="" type="checkbox"/>
NO CE	<input checked="" type="checkbox"/>
MANUAL	<input checked="" type="checkbox"/>
RADIO	<input checked="" type="checkbox"/>

MODELS	LIFTING MOMENT	MAX VERTICAL REACH (HYDR)	SLEWING ANGLE	SLEWING TIME	MAX WORKING HEEL	WORKING PRESSURE	CRANE WEIGHT WITHOUT STABILIZERS	OIL TANK CAPACITY	OIL FLOW	DIMENSIONS
	tm	m	°	s/180°	°	bar	kg	l	l/min	mm B x h x S
HT112 E2	10,2	9,2	425	20	4	300	1060	75	40	2310x2320x830
HT112 E3	-	11,2	425	20	4	300	1150	75	40	2310x2320x830
HT112 E4	-	13,1	425	20	4	300	1230	75	40	2310x2320x830

HT 130

HT130 E2

kg	13130*	5190	2975	2080
m	1,00	2,53	4,33	6,13

HT130 E3

kg	12970*	4970	2835	1960	1470
m	1,00	2,61	4,41	6,21	8,19

HT130 E4

kg	12820*	4765	2705	1850	1370	1090
m	1,00	2,69	4,49	6,29	8,27	10,25

*) Theoretical lifting capacity

CE	<input checked="" type="checkbox"/>
NO CE	<input checked="" type="checkbox"/>
MANUAL	<input checked="" type="checkbox"/>
RADIO	<input checked="" type="checkbox"/>

MODELS	LIFTING MOMENT	MAX VERTICAL REACH (HYDR)	SLEWING ANGLE	SLEWING TIME	MAX WORKING HEEL	WORKING PRESSURE	CRANE WEIGHT WITHOUT STABILIZERS	OIL TANK CAPACITY	OIL FLOW	DIMENSIONS
	tm	m	°	s/180°	°	bar	kg	l	l/min	mm B x h x S
HT130 E2	13,1	9,80	425	20	4	285	1285	130	60	2475x2300x830
HT130 E3	-	11,8	425	20	4	285	1385	130	60	2475x2300x830
HT130 E4	-	13,8	425	20	4	285	1480	130	60	2475x2300x830

HT 162

SDS

HT162 E2

kg	16450*	6500	3740	2625
m	1,00	2,53	4,33	6,13

HT162 E3

kg	16270*	6235	3580	2490	1870
m	1,00	2,61	4,41	6,21	8,19

HT162 E4

kg	15980*	5940	3405	2345	1740	1390
m	1,00	2,69	4,49	6,29	8,27	10,25

*) Theoretical lifting capacity

CE	<input checked="" type="checkbox"/>
NO CE	<input checked="" type="checkbox"/>
MANUAL	<input checked="" type="checkbox"/>
RADIO	<input checked="" type="checkbox"/>

MODELS	LIFTING MOMENT	MAX VERTICAL REACH (HYDR)	SLEWING ANGLE	SLEWING TIME	MAX WORKING HEEL	WORKING PRESSURE	CRANE WEIGHT WITHOUT STABILIZERS	OIL TANK CAPACITY	OIL FLOW	DIMENSIONS
	tm	m	°	s/180°	°	bar	kg	l	l/min	
HT162 E2	16,5	9,8	425	20	4	290	1370	130	60	2485x2300x840
HT162 E3	-	11,8	425	20	4	290	1485	130	60	2485x2300x840
HT162 E4	-	13,8	425	20	4	290	1575	130	60	2485x2300x840

HT 212

SDS

HT212 E2

kg	20230*	8335	4790	3360
m	1,00	2,42	4,22	6,02

HT212 E3

kg	20770*	8250	4750	3400	2495
m	1,00	2,51	4,31	6,11	8,04

HT212 E4

kg	20540*	7930	4660	3250	2440	1895
m	1,00	2,59	4,39	6,19	8,13	10,07

HT212 E5

kg	19000*	7115	4220	2935	2170	1755	1375
m	1,00	2,67	4,47	6,27	8,21	10,15	12,08

*) Theoretical lifting capacity

CE	<input checked="" type="checkbox"/>
NO CE	<input checked="" type="checkbox"/>
MANUAL	<input checked="" type="checkbox"/>
RADIO	<input checked="" type="checkbox"/>

MODELS	LIFTING MOMENT	MAX VERTICAL REACH (HYDR)	SLEWING ANGLE	SLEWING TIME	MAX WORKING HEEL	WORKING PRESSURE	CRANE WEIGHT WITHOUT STABILIZERS	OIL TANK CAPACITY	OIL FLOW	DIMENSIONS
	tm	m	°	s/180°	°	bar	kg	l	l/min	mm B x h x S
HT212 E2	20,2	9,7	415	20	4	315	1680	130	70	2510x2400x870
HT212 E3	-	11,7	415	20	4	315	1825	130	70	2510x2400x870
HT212 E4	-	13,7	415	20	4	315	1945	130	70	2540x2400x870
HT212 E5	-	15,7	415	20	4	300	2040	130	70	2540x2400x870

HT 240

SDS
LCS

HT240 E2

kg	21070	8480	4930	3500
m	1,00*	2,42	4,22	6,02

HT240 E3

kg	21080	8390	4890	3440	2630
m	1,00*	2,51	4,31	6,11	8,04

HT240 E4

kg	20910	8075	4705	3295	2490	2000
m	1,00*	2,59	4,39	6,19	8,13	10,07

HT240 E5

kg	19440*	7250	4350	3020	2260	1820	1485
m	1,00	2,67	4,47	6,27	8,21	10,15	12,08

*) Theoretical lifting capacity

CE	<input checked="" type="checkbox"/>
NO CE	<input checked="" type="checkbox"/>
MANUAL	<input checked="" type="checkbox"/>
RADIO	<input checked="" type="checkbox"/>

MODELS	LIFTING MOMENT	MAX VERTICAL REACH (HYDR)	SLEWING ANGLE	SLEWING TIME	MAX WORKING HEEL	WORKING PRESSURE	CRANE WEIGHT WITHOUT STABILIZERS	OIL TANK CAPACITY	OIL FLOW	DIMENSIONS
	tm	m	°	s/180°	°	bar	kg	l	l/min	
HT240 E2	20,5	9,7	415	20	4	335	1680	130	70	2520x2400x870
HT240 E3	-	11,7	415	20	4	335	1825	130	70	2520x2400x870
HT240 E4	-	13,7	415	20	4	335	1945	130	70	2540x2400x870
HT240 E5	-	15,7	415	20	4	320	2040	130	70	2540x2400x870



HB

HB 31	HB 150
HB 38	HB 160
HB 40	HB 170
HB 50	HB 200
HB 60	HB 210
HB 70	HB 230
HB 80	HB 240
HB 90	HB 250
HB 100	HB 280
HB 112	HB 460
HB 120	HB 700
HB 130	

The most versatile and user-friendly crane, simple, efficient and robust

HB 31



Model	kg	2610*	820	575	420	310	
HB31 E1	m	1,00	3,18	4,53	5,98	7,43	
Model	kg	2510*	765	530	405	310	
HB31 E2	m	1,00	3,28	4,63	5,98	7,43	
Model	kg	2420*	715	490	370	300	220
HB31 E3	m	1,00	3,38	4,73	6,03	7,38	8,78

CE	<input checked="" type="checkbox"/>
NO CE	<input checked="" type="checkbox"/>
MANUAL	<input checked="" type="checkbox"/>
RADIO	<input checked="" type="checkbox"/>

*) Theoretical lifting capacity

MODELS	LIFTING MOMENT	MAX VERTICAL REACH (HYDR)	SLEWING ANGLE	SLEWING TIME	MAX WORKING HEEL	WORKING PRESSURE	CRANE WEIGHT WITHOUT STABILIZERS	OIL TANK CAPACITY	OIL FLOW	DIMENSIONS
	tm	m	°	s/180°	°	bar	kg	l	l/min	mm B x h x S
HB31 E1	2,61	6,98	370	10	4	175	390	25	8	1860x1590x490
HB31 E2	-	8,32	370	10	4	175	425	25	8	1920x1590x490
HB31 E3	-	9,66	370	10	4	175	455	25	8	2000x1590x490

HB 38



HB38 E1

kg	2760*	1360	865	610	450	335
m	1,00	2,00	3,18	4,53	5,98	7,43

HB38 E2

kg	2660*	1315	810	565	435	335
m	1,00	2,00	3,28	4,63	5,98	7,43

HB38 E3

kg	2570*	1265	760	525	400	325	235
m	1,00	2,00	3,38	4,73	6,03	7,38	8,78

*) Theoretical lifting capacity

CE	<input checked="" type="checkbox"/>
NO CE	<input checked="" type="checkbox"/>
MANUAL	<input checked="" type="checkbox"/>
RADIO	<input checked="" type="checkbox"/>

MODELS	LIFTING MOMENT	MAX VERTICAL REACH (HYDR)	SLEWING ANGLE	SLEWING TIME	MAX WORKING HEEL	WORKING PRESSURE	CRANE WEIGHT WITHOUT STABILIZERS	OIL TANK CAPACITY	OIL FLOW	DIMENSIONS mm B x h x S
	tm	m	°	s/180°	°	bar	kg	l	l/min	
HB38 E1	2,75	7,0	370	10	4	185	390	25	8	1860x1590x490
HB38 E2	-	8,3	370	10	4	185	425	25	8	1920x1590x490
HB38 E3	-	9,7	370	10	4	185	455	25	8	2000x1590x490

HB 40



HB40 E1

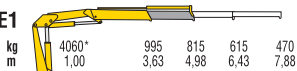

HB40 E2

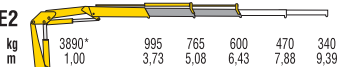

HB40 E3

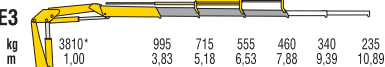

*) Theoretical lifting capacity

CE	<input checked="" type="checkbox"/>
NO CE	<input checked="" type="checkbox"/>
MANUAL	<input checked="" type="checkbox"/>
RADIO	<input checked="" type="checkbox"/>

MODELS	LIFTING MOMENT	MAX VERTICAL REACH (HYDR)	SLEWING ANGLE	SLEWING TIME	MAX WORKING HEEL	WORKING PRESSURE	CRANE WEIGHT WITHOUT STABILIZERS	OIL TANK CAPACITY	OIL FLOW	DIMENSIONS
	tm	m	°	s/180°	°	bar	kg	l	l/min	mm B x h x S
HB40 E1	4,06	7,75	370	15	3	215	515	30	16	1966x1780x500
HB40 E2	-	9,14	370	15	3	215	560	30	16	1966x1780x500
HB40 E3	-	10,51	370	15	3	215	600	30	16	2300x1780x620

HB 50



HB50 E1

kg	4730*	1890**	1300	950	700	520
m	1,00	2,43	3,63	4,98	6,43	7,88

HB50 E2

kg	4460*	1785**	1195	865	680	520	350
m	1,00	2,43	3,73	5,08	6,43	7,88	9,39

HB50 E3

kg	4250*	1700**	1110	800	620	510	350	240
m	1,00	2,43	3,83	5,18	6,53	7,88	9,39	10,89

*) Theoretical lifting capacity

**) Fixed hook capacity

CE	<input checked="" type="checkbox"/>
NO CE	<input checked="" type="checkbox"/>
MANUAL	<input checked="" type="checkbox"/>
RADIO	<input checked="" type="checkbox"/>

MODELS	LIFTING MOMENT	MAX VERTICAL REACH (HYDR)	SLEWING ANGLE	SLEWING TIME	MAX WORKING HEEL	WORKING PRESSURE	CRANE WEIGHT WITHOUT STABILIZERS	OIL TANK CAPACITY	OIL FLOW	DIMENSIONS
	tm	m	°	s/180°	°	bar	kg	l	l/min	mm B x h x S
HB50 E1	4,73	7,75	370	15	3	250	515	30	16	1966x1780x500
HB50 E2	-	9,14	370	15	3	250	560	30	16	1966x1780x500
HB50 E3	-	10,51	370	15	3	250	600	30	16	2300x1780x620

HB 60



Model	kg	1,00	2,45	3,78	5,34	7,00	8,64			
HB60 E1	6580*	2680**	1740	1230	885	655				
m	1,00	2,45	3,78	5,34	7,00	8,64				
HB60 E2	6410*	2615**	1650	1150	885	655	490			
m	1,00	2,45	3,88	5,45	7,00	8,64	10,30			
HB60 E3	6160*	2515**	1555	1070	810	655	490	400		
m	1,00	2,45	3,95	5,50	7,08	8,64	10,30	11,90		
HB60 E4	5970*	2435**	1475	995	745	590	495	400		
m	1,00	2,45	4,05	5,60	7,20	8,73	10,30	11,90		

CE	<input checked="" type="checkbox"/>
NO CE	<input checked="" type="checkbox"/>
MANUAL	<input checked="" type="checkbox"/>
RADIO	<input checked="" type="checkbox"/>

*) Theoretical lifting capacity
 **) Fixed hook capacity

MODELS	LIFTING MOMENT	MAX VERTICAL REACH (HYDR)	SLEWING ANGLE	SLEWING TIME	MAX WORKING HEEL	WORKING PRESSURE	CRANE WEIGHT WITHOUT STABILIZERS	OIL TANK CAPACITY	OIL FLOW	DIMENSIONS
	tm	m	°	s/180°	°	bar	kg	l	l/min	mm B x h x S
HB60 E1	6,58	8,34	387	15	4	245	800	35	20	2240x1980x600
HB60 E2	-	9,81	387	15	4	245	870	35	20	2240x1980x600
HB60 E3	-	11,34	387	15	4	245	930	35	20	2240x1980x600
HB60 E4	-	12,90	387	15	4	245	980	35	20	2250x1980x600

HB 70



HB70 E1

kg	7170*	2925**	1865	1300	945	705
m	1,00	2,45	3,84	5,40	7,02	8,66

HB70 E2

kg	6870*	2805**	1760	1230	945	705	530
m	1,00	2,45	3,90	5,46	7,02	8,66	10,30

HB70 E3

kg	6620*	2700**	1675	1155	870	705	530	415
m	1,00	2,45	3,95	5,50	7,10	8,66	10,30	11,90

HB70 E4

kg	6470*	2620**	1585	1075	800	635	530	415
m	1,00	2,45	4,08	5,60	7,20	8,76	10,30	11,90

*) Theoretical lifting capacity

**) Fixed hook capacity

CE	<input checked="" type="checkbox"/>
NO CE	<input checked="" type="checkbox"/>
MANUAL	<input checked="" type="checkbox"/>
RADIO	<input checked="" type="checkbox"/>

MODELS	LIFTING MOMENT	MAX VERTICAL REACH (HYDR)	SLEWING ANGLE	SLEWING TIME	MAX WORKING HEEL	WORKING PRESSURE	CRANE WEIGHT WITHOUT STABILIZERS	OIL TANK CAPACITY	OIL FLOW	DIMENSIONS
	tm	m	°	s/180°	°	bar	kg	l	l/min	mm B x h x S
HB70 E1	7,17	8,50	387	15	4	265	820	35	20	2310x1980x600
HB70 E2	-	10,20	387	15	4	265	900	35	20	2310x1980x600
HB70 E3	-	11,70	387	15	4	265	960	35	20	2310x1980x600
HB70 E4	-	13,30	387	15	4	265	1020	35	20	2310x1980x600

HB 80



HB80 E1

kg	7890*	3220**	2050	1445	1050	790
m	1,00	2,45	3,85	5,40	7,05	8,66

HB80 E2

kg	7690*	3140**	1965	1370	1050	790	600
m	1,00	2,45	3,90	5,46	7,05	8,66	10,35

HB80 E3

kg	7420*	3030**	1865	1290	975	790	600	470
m	1,00	2,45	3,98	5,55	7,10	8,66	10,35	11,95

HB80 E4

kg	7190*	2935**	1760	1200	900	715	600	470
m	1,00	2,45	4,08	5,65	7,20	8,76	10,35	11,95

*) Theoretical lifting capacity
 **) Fixed hook capacity

CE	<input checked="" type="checkbox"/>
NO CE	<input checked="" type="checkbox"/>
MANUAL	<input checked="" type="checkbox"/>
RADIO	<input checked="" type="checkbox"/>

MODELS	LIFTING MOMENT	MAX VERTICAL REACH (HYDR)	SLEWING ANGLE	SLEWING TIME	MAX WORKING HEEL	WORKING PRESSURE	CRANE WEIGHT WITHOUT STABILIZERS	OIL TANK CAPACITY	OIL FLOW	DIMENSIONS
	tm	m	°	s/180°	°	bar	kg	l	l/min	mm B x h x S
HB80 E1	7,89	8,50	387	15	4	285	850	35	20	2310x1980x600
HB80 E2	-	10,20	387	15	4	285	930	35	20	2310x1980x600
HB80 E3	-	11,70	387	15	4	285	990	35	20	2310x1980x600
HB80 E4	-	13,30	387	15	4	285	1050	35	20	2310x1980x600

HB 90

EES
SDS

HB90 E1

kg	8700*	2130	1510
m	1,00	4,08	5,76

HB90 E2

kg	8240*	2020	1415	1095	710	600
m	1,00	4,08	5,76	7,45	9,41	11,21

HB90 E3

kg	8010*	1920	1716	900	790	600	475
m	1,00	4,11	5,79	7,54	9,34	11,21	13,22

HB90 E4

kg	7840*	1850	1230	920	710	600	475
m	1,00	4,24	5,92	7,61	9,41	11,21	13,22

*) Theoretical lifting capacity

CE	<input checked="" type="checkbox"/>
NO CE	<input checked="" type="checkbox"/>
MANUAL	<input checked="" type="checkbox"/>
RADIO	<input checked="" type="checkbox"/>

MODELS	LIFTING MOMENT	MAX VERTICAL REACH (HYDR)	SLEWING ANGLE	SLEWING TIME	MAX WORKING HEEL	WORKING PRESSURE	CRANE WEIGHT WITHOUT STABILIZERS	OIL TANK CAPACITY	OIL FLOW	DIMENSIONS mm B x h x S
	tm	m	°	s/180°	°	bar	kg	l	l/min	
HB90 E1	8,7	9,1	425	20	4	310	1030	75	40	2305X2070X840
HB90 E2	-	10,7	425	20	4	310	1110	75	40	2305X2070X840
HB90 E3	-	12,6	425	20	4	310	1190	75	40	2305X2070X840
HB90 E4	-	14,4	425	20	4	310	1260	75	40	2305X2070X840

HB 100

EES



HB100 E1

kg	9570*	4400**	2335	1615
m	1,00	2,15	4,10	5,84

HB100 E2

kg	9140*	4195**	2230	1525	1140	815	595	435
m	1,00	2,15	4,10	5,84	7,64	9,60	11,70	13,80

HB100 E3

kg	8800*	4070**	2095	1390	1030	815	595	435
m	1,00	2,15	4,20	5,94	7,74	9,60	11,70	13,80

HB100 E4

kg	8470*	3925**	1970	1300	940	730	595	435
m	1,00	2,15	4,30	6,04	7,85	9,70	11,70	13,80

HB100 E5

kg	8150*	3785**	1860	1205	860	650	520	435
m	1,00	2,15	4,38	6,14	7,95	9,80	11,65	13,65

*) Theoretical lifting capacity

**) Fixed hook capacity

CE	<input type="checkbox"/>
NO CE	<input checked="" type="checkbox"/>
MANUAL	<input checked="" type="checkbox"/>
RADIO	<input checked="" type="checkbox"/>

MODELS	LIFTING MOMENT	MAX VERTICAL REACH (HYDR)	SLEWING ANGLE	SLEWING TIME	MAX WORKING HEEL	WORKING PRESSURE	CRANE WEIGHT WITHOUT STABILIZERS	OIL TANK CAPACITY	OIL FLOW	DIMENSIONS
	tm	m	°	s/180°	°	bar	kg	l	l/min	mm B x h x S
HB100 E1	9,57	9,45	395	17	4	290	1080	60	25	2480x2170x640
HB100 E2	-	11,30	395	17	4	290	1185	60	25	2480x2170x640
HB100 E3	-	13,20	395	17	4	290	1280	60	25	2480x2170x640
HB100 E4	-	15,30	395	17	4	290	1370	60	25	2480x2170x640
HB100 E5	-	17,30	395	17	4	290	1440	60	25	2480x2170x750

HB 112

EES
SDS
HB112 E1

kg	10575*	2580	1820
m	1,00	4,10	5,79

HB112 E2

kg	10170*	2475	1715	1320	865	720
m	1,00	4,11	5,79	7,48	9,36	11,23

HB112 E3

kg	9570*	2280	1565	1185	945	720	575
m	1,00	4,19	5,87	7,56	9,36	11,23	13,27

HB112 E4

kg	9565*	2170	1475	1100	865	715	575
m	1,00	4,27	5,95	7,64	9,44	11,24	13,27

*) Theoretical lifting capacity

CE	<input checked="" type="checkbox"/>
NO CE	<input checked="" type="checkbox"/>
MANUAL	<input checked="" type="checkbox"/>
RADIO	<input checked="" type="checkbox"/>

MODELS	LIFTING MOMENT	MAX VERTICAL REACH (HYDR)	SLEWING ANGLE	SLEWING TIME	MAX WORKING HEEL	WORKING PRESSURE	CRANE WEIGHT WITHOUT STABILIZERS	OIL TANK CAPACITY	OIL FLOW	DIMENSIONS
	tm	m	°	s/180°	°	bar	kg	l	l/min	mm B x h x S
HB112 E1	10,5	9,2	425	20	4	310	1080	75	40	2310X2100X840
HB112 E2	-	10,8	425	20	4	310	1180	75	40	2310X2100X840
HB112 E3	-	12,6	425	20	4	310	1270	75	40	2310X2100X840
HB112 E4	-	14,4	425	20	4	310	1360	75	40	2310X2100X840

HB 120

EES



HB120 E1

kg	11830*	4825**	2790	1940
m	1,00	2,45	4,24	6,04

HB120 E2

kg	11250*	4560**	2605	1825	1375	1005	735	545
m	1,00	2,45	4,32	6,13	8,00	10,06	12,13	14,32

HB120 E3

kg	10960*	4415**	2485	1725	1275	1005	735	545	300
m	1,00	2,45	4,41	6,21	8,08	10,06	12,13	14,32	16,43

HB120 E4

kg	10670*	4295**	2370	1605	1170	895	735	545	300
m	1,00	2,45	4,50	6,30	8,17	10,15	12,13	14,32	16,44

HB120 E5

kg	10510*	4230**	2295	1555	1120	840	670	545	300
m	1,00	2,45	4,58	6,38	8,25	10,23	12,21	14,21	16,44

HB120 E3J2

kg						450	395	350	280
m						12,75	14,12	15,60	17,20

*) Theoretical lifting capacity
 **) Fixed hook capacity

CE	<input checked="" type="checkbox"/>
NO CE	<input checked="" type="checkbox"/>
MANUAL	<input checked="" type="checkbox"/>
RADIO	<input checked="" type="checkbox"/>

MODELS	LIFTING MOMENT	MAX VERTICAL REACH (HYDR)	SLEWING ANGLE	SLEWING TIME	MAX WORKING HEEL	WORKING PRESSURE	CRANE WEIGHT WITHOUT STABILIZERS	OIL TANK CAPACITY	OIL FLOW	DIMENSIONS
	tm	m	°	s/180°	°	bar	kg	l	l/min	mm B x h x S
HB120 E1	11,8	9,6	380	17	4	310	1285	100	25	2460x2340x885
HB120 E2	-	11,5	380	17	4	310	1415	100	25	2460x2340x885
HB120 E3	-	13,5	380	17	4	310	1535	100	25	2470x2340x885
HB120 E4	-	15,5	380	17	4	310	1635	100	25	2485x2340x885
HB120 E5	-	17,6	380	17	4	310	1705	100	25	2500x2340x940
HB120 E3J2	-	18,8	380	17	4	290	1835	100	25	2490x2340x1030

HB 130

EES
SDS

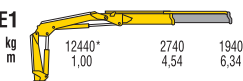
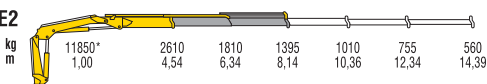
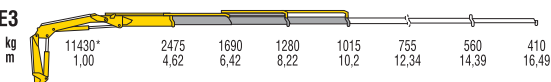
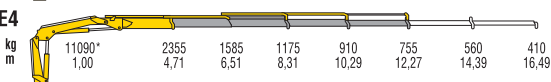
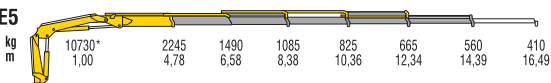
HB130 E1

HB130 E2

HB130 E3

HB130 E4

HB130 E5

*) Theoretical lifting capacity

CE	<input checked="" type="checkbox"/>
NO CE	<input checked="" type="checkbox"/>
MANUAL	<input checked="" type="checkbox"/>
RADIO	<input checked="" type="checkbox"/>

MODELS	LIFTING MOMENT	MAX VERTICAL REACH (HYDR)	SLEWING ANGLE	SLEWING TIME	MAX WORKING HEEL	WORKING PRESSURE	CRANE WEIGHT WITHOUT STABILIZERS	OIL TANK CAPACITY	OIL FLOW	DIMENSIONS
	tm	m	°	s/180°	°	bar	kg	l	l/min	
HB130 E1	12,4	9,9	425	20	4	285	1335	130	60	2480x2295x825
HB130 E2	-	11,7	425	20	4	285	1445	130	60	2480x2295x825
HB130 E3	-	13,7	425	20	4	285	1570	130	60	2480x2295x825
HB130 E4	-	15,7	425	20	4	285	1660	130	60	2480x2295x825
HB130 E5	-	17,8	425	20	4	285	1745	130	60	2480x2295x895

HB 150



HB150 E1

kg 13890* 5660** 3275 2275
m 1,00 2,45 4,24 6,04

HB150 E2

kg 13240* 5405** 3065 2130 1620 1190 885 610
m 1,00 2,45 4,32 6,13 8,00 10,06 12,13 14,32

HB150 E3

kg 12880* 5200** 2920 2010 1495 1190 885 610 380
m 1,00 2,45 4,41 6,21 8,08 10,06 12,13 14,32 16,43

HB150 E4

kg 12690* 5100** 2820 1895 1385 1075 885 610 380
m 1,00 2,45 4,50 6,30 8,17 10,15 12,13 14,32 16,44

HB150 E5

kg 12390* 5000** 2705 1805 1295 995 805 615 380
m 1,00 2,45 4,58 6,38 8,25 10,23 12,21 14,21 16,44

HB150 E3J2

kg 550 485 430 360
m 12,75 14,12 15,60 17,20

*) Theoretical lifting capacity
**) Fixed hook capacity

CE	<input checked="" type="checkbox"/>
NO CE	<input checked="" type="checkbox"/>
MANUAL	<input checked="" type="checkbox"/>
RADIO	<input checked="" type="checkbox"/>

MODELS	LIFTING MOMENT	MAX VERTICAL REACH (HYDR)	SLEWING ANGLE	SLEWING TIME	MAX WORKING HEEL	WORKING PRESSURE	CRANE WEIGHT WITHOUT STABILIZERS	OIL TANK CAPACITY	OIL FLOW	DIMENSIONS
	tm	m	°	s/180°	°	bar	kg	l	l/min	mm B x h x S
HB150 E1	13,9	9,6	380	17	4	290	1470	100	25	2460x2340x885
HB150 E2	-	11,5	380	17	4	290	1600	100	25	2460x2340x885
HB150 E3	-	13,5	380	17	4	290	1720	100	25	2470x2340x885
HB150 E4	-	15,5	380	17	4	290	1820	100	25	2485x2340x885
HB150 E5	-	17,6	380	17	4	290	1900	100	25	2500x2340x940
HB150 E3J2	-	18,8	380	17	4	270	2030	100	25	2490x2340x1030

HB 160

EES
SDS

HB160 E1

kg	15840*	3490	2475
m	1,00	4,54	6,34

HB160 E2

kg	15030*	3310	2305	1775	1305	980	740
m	1,00	4,54	6,34	8,14	10,36	12,34	14,39

HB160 E3

kg	14550*	3150	2170	1645	1305	980	740	535
m	1,00	4,62	6,42	8,22	10,2	12,34	14,39	16,49

HB160 E4

kg	14150*	3005	2040	1520	1185	980	740	535
m	1,00	4,71	6,51	8,31	10,29	12,27	14,39	16,49

HB160 E5

kg	13740*	2875	1925	1410	1080	875	740	535
m	1,00	4,78	6,58	8,38	10,36	12,34	14,39	16,49

*) Theoretical lifting capacity

CE	<input checked="" type="checkbox"/>
NO CE	<input checked="" type="checkbox"/>
MANUAL	<input checked="" type="checkbox"/>
RADIO	<input checked="" type="checkbox"/>

MODELS	LIFTING MOMENT	MAX VERTICAL REACH (HYDR)	SLEWING ANGLE	SLEWING TIME	MAX WORKING HEEL	WORKING PRESSURE	CRANE WEIGHT WITHOUT STABILIZERS	OIL TANK CAPACITY	OIL FLOW	DIMENSIONS
	tm	m	°	s/180°	°	bar	kg	l	l/min	
HB160 E1	15,8	9,9	425	20	4	280	1525	130	60	2490x2295x825
HB160 E2	-	11,7	425	20	4	280	1660	130	60	2490x2295x825
HB160 E3	-	13,7	425	20	4	280	1775	130	60	2490x2295x825
HB160 E4	-	15,7	425	20	4	280	1880	130	60	2490x2295x825
HB160 E5	-	17,8	425	20	4	280	1970	130	60	2490x2295x905

HB 170

EES
SDS



HB170 E1

kg	15760*	7470**	3700	2560
m	1,00	2,10	4,26	6,13

HB170 E2

kg	15340*	7215**	3600	2445	1850
m	1,00	2,10	4,26	6,13	8,00

HB170 E3

kg	15040*	7040**	3530	2355	1750	1380	1045	795	600
m	1,00	2,10	4,26	6,13	8,00	9,95	11,90	14,00	16,10

HB170 E4

kg	14680*	6900**	3445	2255	1640	1270	1045	795	600	460
m	1,00	2,10	4,26	6,13	8,00	9,95	11,90	14,00	16,10	18,30

HB170 E5

kg	14360*	6740**	3300	2130	1525	1170	940	795	600	460
m	1,00	2,10	4,35	6,22	8,10	10,05	12,00	14,00	16,10	18,30

HB170 E6

kg	14010*	6580**	3170	2030	1435	1070	850	700	600	460
m	1,00	2,10	4,42	6,30	8,16	10,10	12,10	14,10	16,10	18,30

HB170 E4J2

kg										535	480	435	360
m										14,60	16,00	17,50	19,10

CE	<input checked="" type="checkbox"/>
NO CE	<input checked="" type="checkbox"/>
MANUAL	<input checked="" type="checkbox"/>
RADIO	<input checked="" type="checkbox"/>

*) Theoretical lifting capacity
**) Fixed hook capacity

HB 170



EES Extra Extension Speed
SDS Smooth Descent System

MODELS	LIFTING MOMENT	MAX VERTICAL REACH (HYDR)	SLEWING ANGLE	SLEWING TIME	MAX WORKING HEEL	WORKING PRESSURE	CRANE WEIGHT WITHOUT STABILIZERS	OIL TANK CAPACITY	OIL FLOW	DIMENSIONS
	tm	m	°	s/180°	°	bar	kg	l	l/min	mm B x h x S
HB170 E1	15,8	9,9	387	17	4	310	1770	130	32	2480x2295x970
HB170 E2	-	11,8	387	17	4	310	1910	130	32	2480x2295x970
HB170 E3	-	13,8	387	17	4	310	2030	130	32	2480x2295x1000
HB170 E4	-	15,7	387	17	4	310	2150	130	32	2480x2295x1000
HB170 E5	-	17,8	387	17	4	310	2260	130	32	2480x2295x1000
HB170 E6	-	19,8	387	17	4	310	2340	130	32	2495x2295x1000
HB170 E4J2	-	21,2	387	17	4	310	2460	130	32	2480x2295x1120

HB 200

EES
SDS



HB200 E1

kg	19620*	9210**	4605	3200
m	1,00	2,10	4,26	6,13

HB200 E2

kg	19170*	9060**	4500	3095	2325
m	1,00	2,10	4,26	6,13	8,00

HB200 E3

kg	18660*	8750**	4380	2945	2205	1740	1325	1005	770
m	1,00	2,10	4,26	6,13	8,00	9,95	11,90	14,00	16,10

HB200 E4

kg	18210*	8575**	4275	2845	2085	1605	1325	1005	770	550
m	1,00	2,10	4,26	6,13	8,00	9,95	11,90	14,00	16,10	18,30

HB200 E5

kg	17790*	8370**	4090	2680	1940	1490	1195	1005	770	550
m	1,00	2,10	4,35	6,22	8,10	10,05	12,00	14,00	16,10	18,30

HB200 E6

kg	17390*	8190**	3935	2570	1840	1395	1105	915	775	550
m	1,00	2,10	4,42	6,30	8,16	10,10	12,10	14,10	16,10	18,30

HB200 E5J2

kg									550	500	450	380
m									16,70	18,10	19,60	21,10

*) Theoretical lifting capacity
**) Fixed hook capacity

CE	<input checked="" type="checkbox"/>
NO CE	<input checked="" type="checkbox"/>
MANUAL	<input checked="" type="checkbox"/>
RADIO	<input checked="" type="checkbox"/>

HB 200



EES Extra Extension Speed

SDS Smooth Descent System

MODELS	LIFTING MOMENT	MAX VERTICAL REACH (HYDR)	SLEWING ANGLE	SLEWING TIME	MAX WORKING HEEL	WORKING PRESSURE	CRANE WEIGHT WITHOUT STABILIZERS	OIL TANK CAPACITY	OIL FLOW	DIMENSIONS
	tm	m	°	s/180°	°	bar	kg	l	l/min	mm B x h x S
HB200 E1	19,6	9,9	387	17	4	300	1860	130	40	2480x2295x970
HB200 E2	-	11,8	387	17	4	300	2010	130	40	2480x2295x970
HB200 E3	-	13,8	387	17	4	300	2150	130	40	2480x2295x1000
HB200 E4	-	15,7	387	17	4	300	2280	130	40	2480x2295x1000
HB200 E5	-	17,8	387	17	4	300	2380	130	40	2480x2295x1000
HB200 E6	-	19,8	387	17	4	300	2480	130	40	2495x2295x1000
HB200 E5J2	-	23,3	387	17	4	300	2715	130	40	2480x2300x1120

HB 210

EES
SDS



HB210 E2

kg	18940*	4405	3000	2280
m	1,00	4,30	6,20	8,10

HB210 E3

kg	18575*	4320	2970	2230	1700	1280	980	770
m	1,00	4,30	6,20	8,10	10,13	12,25	14,46	16,59

HB210 E4

kg	17995*	4100	2830	2120	1625	1280	980	770	630
m	1,00	4,39	6,29	8,19	10,22	12,25	14,46	16,59	18,70

HB210 E5

kg	17610*	3940	2585	1880	1440	1165	980	770	630
m	1,00	4,47	6,37	8,27	10,30	12,33	14,16	16,59	18,70

CE	<input checked="" type="checkbox"/>
NO CE	<input checked="" type="checkbox"/>
MANUAL	<input checked="" type="checkbox"/>
RADIO	<input checked="" type="checkbox"/>

*) Theoretical lifting capacity

HB 210



EES Extra Extension Speed
SDS Smooth Descent System

MODELS	LIFTING MOMENT	MAX VERTICAL REACH (HYDR)	SLEWING ANGLE	SLEWING TIME	MAX WORKING HEEL	WORKING PRESSURE	CRANE WEIGHT WITHOUT STABILIZERS	OIL TANK CAPACITY	OIL FLOW	DIMENSIONS
	tm	m	°	s/180°	°	bar	kg	l	l/min	mm B x h x S
HB210 E2	18,9	11,9	415	20	4	315	2040	130	70	2520X2300X930
HB210 E3	-	13,9	415	20	4	315	2190	130	70	2520X2300X930
HB210 E4	-	16,1	415	20	4	315	2335	130	70	2520X2300X930
HB210 E5	-	18,2	415	20	4	315	2450	130	70	2520X2300X930

HB 230

EES
SDS
LCS



HB230 E1

kg	20660*	9620**	4765	3370
m	1,00	2,10	4,26	6,13

HB230 E2

kg	19980*	9415**	4665	3260	2490
m	1,00	2,10	4,26	6,13	8,00

HB230 E3

kg	19300*	9140**	4530	3095	2355	1905	1470	1145	905
m	1,00	2,10	4,26	6,13	8,00	9,95	11,90	14,00	16,10

HB230 E4

kg	18870*	8935**	4430	2995	2225	1755	1470	1145	905	650
m	1,00	2,10	4,26	6,13	8,00	9,95	11,90	14,00	16,10	18,30

HB230 E5

kg	18420*	8720**	4235	2820	2075	1635	1330	1145	905	650
m	1,00	2,10	4,35	6,22	8,10	10,05	12,00	14,00	16,10	18,30

HB230 E6

kg	18030*	8525**	4080	2700	1970	1535	1230	1045	905	650
m	1,00	2,10	4,42	6,30	8,16	10,10	12,10	14,10	16,10	18,30

HB230 E5J2

kg									605	550	505	400
m									16,70	18,10	19,60	21,10

CE	<input checked="" type="checkbox"/>
NO CE	<input checked="" type="checkbox"/>
MANUAL	<input checked="" type="checkbox"/>
RADIO	<input checked="" type="checkbox"/>

*) Theoretical lifting capacity
**) Fixed hook capacity

HB 230



EES Extra Extension Speed
SDS Smooth Descent System
LCS Lift Control System

MODELS	LIFTING MOMENT	MAX VERTICAL REACH (HYDR)	SLEWING ANGLE	SLEWING TIME	MAX WORKING HEEL	WORKING PRESSURE	CRANE WEIGHT WITHOUT STABILIZERS	OIL TANK CAPACITY	OIL FLOW	DIMENSIONS
	tm	m	°	s/180°	°	bar	kg	l	l/min	mm B x h x S
HB230 E1	20,7	9,9	387	17	4	315	1890	130	40	2480x2295x970
HB230 E2	-	11,8	387	17	4	315	2040	130	40	2480x2295x970
HB230 E3	-	13,8	387	17	4	315	2180	130	40	2480x2295x1000
HB230 E4	-	15,7	387	17	4	315	2310	130	40	2480x2295x1000
HB230 E5	-	17,8	387	17	4	315	2410	130	40	2480x2295x1000
HB230 E6	-	19,8	387	17	4	315	2510	130	40	2480x2295x1000
HB230 E5J2	-	23,3	387	17	4	315	2745	130	40	2480x2300x1120

HB 240

EES
SDS



HB240 E2

kg	22700*	5280	3610	2750
m	1,00	4,30	6,20	8,10

HB240 E3

kg	21865*	5085	3425	2570	2035	1530	1170	770
m	1,00	4,30	6,20	8,10	10,13	12,25	14,46	16,59

HB240 E4

kg	21155*	4820	3215	2380	1860	1530	1170	915	735
m	1,00	4,39	6,29	8,19	10,22	12,25	14,46	16,59	18,70

HB240 E5

kg	21490*	4585	3035	2220	1710	1390	1170	915	735
m	1,00	4,47	6,37	8,27	10,30	12,33	14,46	16,59	18,70

- CE**
- NO CE**
- MANUAL**
- RADIO**

*) Theoretical lifting capacity

HB 240



EES Extra Extension Speed
SDS Smooth Descent System

MODELS	LIFTING MOMENT	MAX VERTICAL REACH (HYDR)	SLEWING ANGLE	SLEWING TIME	MAX WORKING HEEL	WORKING PRESSURE	CRANE WEIGHT WITHOUT STABILIZERS	OIL TANK CAPACITY	OIL FLOW	DIMENSIONS
	tm	m	°	s/180°	°	bar	kg	l	l/min	mm B x h x S
HB240 E2	18,9	11,9	415	20	4	320	2200	130	80	2520X2300X930
HB240 E3	-	13,9	415	20	4	320	2355	130	80	2520X2300X930
HB240 E4	-	16,0	415	20	4	320	2505	130	80	2520X2300X930
HB240 E5	-	18,2	415	20	4	320	2625	130	80	2520X2300X930

HB 250



HB250 E1

kg	25070*	9580**	5830	4065	2895	2160	1620	1255
m	1,00	2,55	4,30	6,07	7,93	9,82	11,82	13,90

HB250 E2

kg	24670*	9480**	5725	3890	2895	2160	1620	1255
m	1,00	2,55	4,31	6,08	7,93	9,82	11,81	13,90

HB250 E3

kg	24030*	9275**	5575	3740	2750	2160	1620	1255	1005
m	1,00	2,55	4,31	6,08	7,93	9,83	11,82	13,88	15,95

HB250 E4

kg	23390*	9070**	5315	3535	2570	1985	1620	1255	1005	850
m	1,00	2,55	4,40	6,17	8,02	9,92	11,82	13,88	15,95	17,75

HB250 E5

kg	22890*	8970**	5110	3390	2425	1865	1500	1255	1005	850
m	1,00	2,55	4,48	6,25	8,10	10,00	11,90	13,88	15,95	17,75

HB250 E6

kg	22860*	8950**	5035	3320	2375	1805	1445	1205	965	780
m	1,00	2,55	4,54	6,31	8,16	10,06	11,96	13,94	15,92	17,81

HB250 E3J3

kg						1105	925	805	700	500
m						12,30	13,90	15,50	17,20	19,00

HB250 E4J3

kg							835	745	630	565	480
m							14,30	15,80	17,50	19,10	20,90

CE	<input checked="" type="checkbox"/>
NO CE	<input checked="" type="checkbox"/>
MANUAL	<input checked="" type="checkbox"/>
RADIO	<input checked="" type="checkbox"/>

*) Theoretical lifting capacity
 **) Fixed hook capacity

HB 250



MODELS	LIFTING MOMENT	MAX VERTICAL REACH (HYDR)	SLEWING ANGLE	SLEWING TIME	MAX WORKING HEEL	WORKING PRESSURE	CRANE WEIGHT WITHOUT STABILIZERS	OIL TANK CAPACITY	OIL FLOW	DIMENSIONS
	tm	m	°	s/180°	°	bar	kg	l	l/min	mm B x h x S
HB250 E1	25,1	9,8	400	20	4	290	2580	160	50	2540x2320x1115
HB250 E2	-	11,6	400	20	4	290	2760	160	50	2540x2320x1115
HB250 E3	-	13,4	400	20	4	290	2900	160	50	2540x2320x1115
HB250 E4	-	15,3	400	20	4	290	3060	160	50	2540x2320x1115
HB250 E5	-	17,3	400	20	4	290	3200	160	50	2540x2320x1115
HB250 E6	-	19,3	400	20	4	290	3295	160	50	2540x2320x1115
HB250 E3J3	-	20,2	400	25	4	290	3450	160	50	2540x2430x1300
HB250 E4J3	-	22,1	400	25	4	295	3600	160	50	2540x2445x1300

HB 280

LCS



HB280 E1

kg	25820*	9785**	6005	4245	3055	2300	1750	1375	
m	1,00	2,55	4,30	6,07	7,93	9,82	11,82	13,90	

HB280 E2

kg	25430*	9685**	5900	4065	3055	2300	1750	1375	
m	1,00	2,55	4,31	6,08	7,93	9,82	11,81	13,87	

HB280 E3

kg	24780*	9530**	5750	3900	2905	2300	1750	1375	1115
m	1,00	2,55	4,31	6,08	7,93	9,83	11,82	13,88	15,95

HB280 E4

kg	24070*	9325**	5470	3685	2710	2120	1750	1375	1115	955
m	1,00	2,55	4,40	6,17	8,02	9,92	11,82	13,88	15,95	17,75

HB280 E5

kg	23650*	9175**	5275	3545	2570	1995	1620	1365	1115	955
m	1,00	2,55	4,48	6,25	8,10	10,00	11,90	13,88	15,95	17,75

HB280 E6

kg	23650*	9125**	5210	3470	2510	1925	1560	1315	1065	870
m	1,00	2,55	4,54	6,31	8,16	10,06	11,96	13,94	15,92	17,81

HB280 E3J3

kg							1205	1005	885	780	555
m							12,30	13,90	15,50	17,20	19,00

HB280 E4J3

kg								935	830	700	630	530
m								14,30	15,80	17,50	19,10	20,90

*) Theoretical lifting capacity
 **) Fixed hook capacity

CE	<input checked="" type="checkbox"/>
NO CE	<input checked="" type="checkbox"/>
MANUAL	<input checked="" type="checkbox"/>
RADIO	<input checked="" type="checkbox"/>

HB 280



LCS Lift Control System

MODELS	LIFTING MOMENT	MAX VERTICAL REACH (HYDR)	SLEWING ANGLE	SLEWING TIME	MAX WORKING HEEL	WORKING PRESSURE	CRANE WEIGHT WITHOUT STABILIZERS	OIL TANK CAPACITY	OIL FLOW	DIMENSIONS
	tm	m	°	s/180°	°	bar	kg	l	l/min	mm B x h x S
HB280 E1	25,8	9,8	400	20	4	305	2630	160	50	2540x2320x1115
HB280 E2	-	11,6	400	20	4	305	2810	160	50	2540x2320x1115
HB280 E3	-	13,4	400	20	4	305	2950	160	50	2540x2320x1115
HB280 E4	-	15,3	400	20	4	305	3110	160	50	2540x2320x1115
HB280 E5	-	17,3	400	20	4	305	3250	160	50	2540x2320x1115
HB280 E6	-	19,3	400	20	4	305	3345	160	50	2540x2320x1115
HB280 E3J3	-	20,2	400	25	4	295	3500	160	50	2540x2430x1300
HB280 E4J3	-	22,1	400	25	4	295	3650	160	50	2540x2445x1300

HB 460

EES
SDS
LAS



HB460 E2

kg	43420*	22150*	10485	7360	5590
m	1,00	1,95	4,12	5,90	7,75

HB460 E3

kg	42350*	21720*	10010	7025	5310	4220	3270	2565	2040
m	1,00	1,95	4,23	6,00	7,85	9,80	11,80	13,90	16,00

HB460 E4

kg	41780*	21425*	9600	6710	5020	3955	3270	2565	2040	1605
m	1,00	1,95	4,35	6,10	7,95	9,90	11,80	13,90	16,00	18,20

HB460 E5

kg	41400*	21230*	9410	6505	4795	3720	3040	2565	2040	1605	1260
m	1,00	1,95	4,35	6,10	7,95	9,90	11,80	13,90	16,00	18,20	20,40

HB460 E6

kg	40050*	20540*	9095	6245	4580	3515	2845	2360	2040	1605	1260	1005
m	1,00	1,95	4,40	6,15	8,00	9,90	11,90	13,90	16,00	18,20	20,40	22,60

HB460 E7

kg	39230*	20120*	8915	6050	4385	3325	2640	2170	1840	1605	1260	1005
m	1,00	1,95	4,40	6,15	8,00	9,90	11,90	13,90	16,00	18,20	20,40	22,60

HB460 E8

kg	38550*	19770*	8560	5800	4180	3140	2460	1975	1660	1425	1260	1005
m	1,00	1,95	4,50	6,20	8,10	10,00	12,00	14,00	16,10	18,20	20,40	22,60

*) Theoretical lifting capacity

CE	<input checked="" type="checkbox"/>
NO CE	<input checked="" type="checkbox"/>
MANUAL	<input checked="" type="checkbox"/>
RADIO	<input checked="" type="checkbox"/>

HB 460



EES Extra Extension Speed
SDS Smooth Descent System
LAS Liftrod Articulating System

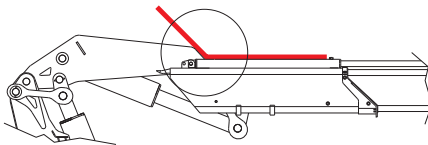

Second boom with negative angle in order to simplify operations in difficult access conditions

MODELS	LIFTING MOMENT	MAX VERTICAL REACH (HYDR)	SLEWING ANGLE	SLEWING TIME	MAX WORKING HEEL	WORKING PRESSURE	CRANE WEIGHT WITHOUT STABILIZERS	OIL TANK CAPACITY	OIL FLOW	DIMENSIONS
	tm	m	°	s/180°	°	bar	kg	l	l/min	
HB460 E2	43,4	12,1	400	22	4	305	4040	210	50	2505x2460x1275
HB460 E3	-	14,1	400	22	4	305	4290	210	50	2505x2460x1275
HB460 E4	-	16,1	400	22	4	305	4570	210	50	2505x2460x1275
HB460 E5	-	18,2	400	22	4	305	4810	210	50	2505x2460x1285
HB460 E6	-	20,3	400	22	4	305	5010	210	50	2505x2460x1285
HB460 E7	-	22,5	400	22	4	305	5200	210	50	2505x2460x1400
HB460 E8	-	24,7	400	22	4	305	5380	210	50	2510x2480x1400

HB 700

EES
SDS
LAS



HB700 E2

kg	69840*	23280*	16890	12050	9250
m	1,00	3,00	4,05	5,75	7,55

HB700 E4

kg	66300*	22100*	16090	11330	8570	6800	5640
m	1,00	3,00	4,12	5,85	7,65	9,55	11,45

HB700 E6

kg	64350*	21450*	15070	10540	7840	6120	5030	4210	3640	2730	2420	1770
m	1,00	3,00	4,27	6,00	7,77	9,70	11,60	13,60	15,60	17,60	19,60	22,00

HB700 E8

kg	62550*	20850*	14650	10120	7400	5660	4520	3710	3130	2730	2420	1770	1610	1265
m	1,00	3,00	4,27	6,00	7,77	9,70	11,60	13,60	15,60	17,60	19,60	22,00	24,15	26,50

HB700 E10

kg	61980*	20660*	13620	9390	6840	5160	4060	3260	2710	2320	2020	1770	1610	1265
m	1,00	3,00	4,55	6,25	8,05	10,00	11,85	13,85	15,85	17,85	19,85	22,00	24,15	26,50

*) Theoretical lifting capacity

CE	<input type="checkbox"/>
NO CE	<input checked="" type="checkbox"/>
MANUAL	<input checked="" type="checkbox"/>
RADIO	<input type="checkbox"/>

HB 700



EES Extra Extension Speed
SDS Smooth Descent System
LAS Liftrod Articulating System

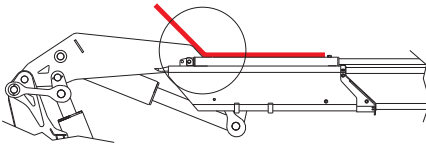

Second boom with negative angle in order to simplify operations in difficult access conditions

MODELS	LIFTING MOMENT	MAX VERTICAL REACH (HYDR)	SLEWING ANGLE	SLEWING TIME	MAX WORKING HEEL	WORKING PRESSURE	CRANE WEIGHT WITHOUT STABILIZERS	OIL TANK CAPACITY	OIL FLOW	DIMENSIONS mm B x h x S
	tm	m	°	s/180°	°	bar	kg	l	l/min	
HB700 E2	69,8	12,1	420	45	4	280	6350	280	80	2530x2450x1950
HB700 E4	-	16,0	420	45	4	280	7000	280	80	2530x2450x1950
HB700 E6	-	20,2	420	45	4	280	7600	280	80	2530x2450x2110
HB700 E8	-	24,1	420	45	4	280	8150	280	80	2530x2505x2135
HB700 E10	-	28,7	420	45	4	280	8550	280	80	2530x2635x2135



HB-R

HB 330R

HB 350R

HB 430R

HB 450R

HB 600R

HB 660R

Large, user-friendly articulated cranes

HB 330R



HB330R E2

kg	31800	15900	7880**	7450	5390	4140	3130	2450	1900
m	1,00	2,00	4,03	4,28	5,88	7,63	9,58	11,53	13,53

HB330R E3

kg	31400	15700	7710**	7150	5140	3920	3130	2450	1900	1400
m	1,00	2,00	4,03	4,38	5,98	7,73	9,58	11,53	13,53	15,53

HB330R E4

kg	31000	15500	7550**	6900	4920	3720	2950	2450	1900	1400	1080
m	1,00	2,00	4,03	4,45	6,08	7,83	9,68	11,53	13,53	15,53	17,53

CE	<input type="checkbox"/>
NO CE	<input checked="" type="checkbox"/>
MANUAL	<input checked="" type="checkbox"/>
RADIO	<input checked="" type="checkbox"/>

*) Theoretical lifting capacity

**) Fixed hook capacity

MODELS	LIFTING MOMENT	MAX VERTICAL REACH (HYDR)	SLEWING ANGLE	SLEWING TIME	MAX WORKING HEEL	WORKING PRESSURE	CRANE WEIGHT WITHOUT STABILIZERS	OIL TANK CAPACITY	OIL FLOW	DIMENSIONS
	tm	m	°	s/180°	°	bar	kg	l	l/min	mm B x h x S
HB330R E2	31,8	11,6	380	20	4	290	3145	160	50	2550x2490x1175
HB330R E3	-	13,5	380	20	4	290	3370	160	50	2550x2490x1175
HB330R E4	-	15,4	380	20	4	290	3580	160	50	2550x2490x1175

HB 350R

LCS

HB350R E2

kg	32800	16400*	8100**	7680	5580	4300	3270	2560	2010
m	1,00	2,00	4,03	4,28	5,88	7,63	9,58	11,53	13,53

HB350R E3

kg	32200	16100*	7930**	7350	5300	4070	3270	2560	2010	1495
m	1,00	2,00	4,03	4,38	5,98	7,73	9,58	11,53	13,53	15,53

HB350R E4

kg	31600	15800*	7790**	7100	5060	3850	3060	2560	2010	1495	1160
m	1,00	2,00	4,03	4,45	6,08	7,83	9,68	11,53	13,53	15,53	17,53

*) Theoretical lifting capacity

**) Fixed hook capacity

CE	<input type="checkbox"/>
NO CE	<input checked="" type="checkbox"/>
MANUAL	<input checked="" type="checkbox"/>
RADIO	<input checked="" type="checkbox"/>

MODELS	LIFTING MOMENT	MAX VERTICAL REACH (HYDR)	SLEWING ANGLE	SLEWING TIME	MAX WORKING HEEL	WORKING PRESSURE	CRANE WEIGHT WITHOUT STABILIZERS	OIL TANK CAPACITY	OIL FLOW	DIMENSIONS
	tm	m	°	s/180°	°	bar	kg	l	l/min	mm B x h x S
HB350R E2	32,8	11,6	380	20	4	300	3165	160	50	2550x2490x1175
HB350R E3	-	13,5	380	20	4	300	3390	160	50	2550x2490x1175
HB350R E4	-	15,4	380	20	4	300	3600	160	50	2550x2490x1175

HB 430R



HB430R E2

kg	43560*	21780*	10250	7400	5650	4480	3550	2500
m	1,00	2,00	4,25	5,85	7,60	9,55	11,5	13,5

HB430R E3

kg	42800*	21400*	9850	7050	5350	4300	3550	2500	1800
m	1,00	2,00	4,35	5,95	7,70	9,55	11,5	13,5	15,5

HB430R E4

kg	42300*	21150*	9500	6700	5140	4080	3400	2500	1800	1250
m	1,00	2,00	4,45	6,05	7,80	9,65	11,5	13,5	15,5	17,5

HB430R E6

kg	41140*	20570*	9350	6550	5100	3900	3100	2600	2150	1000
m	1,00	2,00	4,40	5,95	7,65	9,50	11,3	13,15	15,0	17,0

*) Theoretical lifting capacity

CE	<input checked="" type="checkbox"/>
NO CE	<input checked="" type="checkbox"/>
MANUAL	<input checked="" type="checkbox"/>
RADIO	<input checked="" type="checkbox"/>

MODELS	LIFTING MOMENT	MAX VERTICAL REACH (HYDR)	SLEWING ANGLE	SLEWING TIME	MAX WORKING HEEL	WORKING PRESSURE	CRANE WEIGHT WITHOUT STABILIZERS	OIL TANK CAPACITY	OIL FLOW	DIMENSIONS
	tm	m	°	s/180°	°	bar	kg	l	l/min	mm B x h x S
HB430R E2	43,6	11,64	385	20	4	250	3835	250	50	2550x2495x1280
HB430R E3	-	13,55	385	20	4	250	4075	250	50	2550x2495x1280
HB430R E4	-	15,46	385	20	4	250	4280	250	50	2550x2495x1280
HB430R E6	-	19,02	385	20	4	270	4690	250	50	2590x2495x1390

HB 450R

LCS

HB450R E2

kg	45480*	22740*	10700	7750	5950	4480	3550	2500
m	1,00	2,00	4,25	5,85	7,60	9,55	11,5	13,5

HB450R E3

kg	44800*	22400*	10300	7400	5600	4480	3550	2500	1800
m	1,00	2,00	4,35	5,95	7,70	9,55	11,5	13,5	15,5

HB450R E4

kg	44640*	22320*	10030	7200	5400	4270	3550	2500	1800	1250
m	1,00	2,00	4,45	6,05	7,80	9,65	11,5	13,5	15,5	17,5

HB450R E6

kg	43560*	21780*	9900	6900	5400	4100	3250	2750	2250	1000
m	1,00	2,00	4,40	5,95	7,65	9,50	11,3	13,15	15,0	17,0

*) Theoretical lifting capacity

CE	<input type="checkbox"/>
NO CE	<input checked="" type="checkbox"/>
MANUAL	<input checked="" type="checkbox"/>
RADIO	<input checked="" type="checkbox"/>

MODELS	LIFTING MOMENT	MAX VERTICAL REACH (HYDR)	SLEWING ANGLE	SLEWING TIME	MAX WORKING HEEL	WORKING PRESSURE	CRANE WEIGHT WITHOUT STABILIZERS	OIL TANK CAPACITY	OIL FLOW	DIMENSIONS
	tm	m	°	s/180°	°	bar	kg	l	l/min	mm B x h x S
HB450R E2	45,5	11,64	385	20	4	270	3885	250	50	2550x2495x1280
HB450R E3	-	13,55	385	20	4	270	4125	250	50	2550x2495x1280
HB450R E4	-	15,46	385	20	4	270	4330	250	50	2550x2495x1280
HB450R E6	-	19,02	385	20	4	270	4690	250	50	2590x2495x1390

HB 600R

LAS



HB600R E4

kg	57400*	28700	12900	9000	6780	5360	4470	3300	2850	2200
m	1,00	2,00	4,45	6,3	8,15	10,15	12,15	14,3	16,4	18,6

HB600R E6

kg	55000*	27500	12200	8340	6200	4820	3940	3300	2850	2200	1680
m	1,00	2,00	4,5	6,35	8,2	10,2	12,2	14,3	16,4	18,6	20,9

HB600R E6 J4

kg											
m	1410	1270	1050	770	610	470					
	19,30	21,00	22,75	24,50	26,30	28,22					

CE	<input checked="" type="checkbox"/>
NO CE	<input checked="" type="checkbox"/>
MANUAL	<input checked="" type="checkbox"/>
RADIO	<input checked="" type="checkbox"/>

*) Theoretical lifting capacity

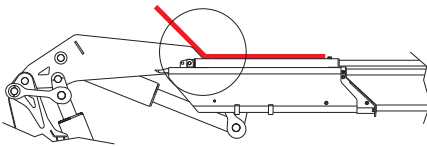

Second boom with negative angle in order to simplify operations in difficult access conditions

MODELS	LIFTING MOMENT	MAX VERTICAL REACH (HYDR)	SLEWING ANGLE	SLEWING TIME	MAX WORKING HEEL	WORKING PRESSURE	CRANE WEIGHT WITHOUT STABILIZERS	OIL TANK CAPACITY	OIL FLOW	DIMENSIONS
	tm	m	°	s/180°	°	bar	kg	l	l/min	mm B x h x S
HB600R E4	57,4	16,0	428	18	4	290	5100	250	70	2550x2420x1465
HB600R E6	-	20,2	428	18	4	290	5600	250	70	2550x2420x1465
HB600R E6J4	-	20,6	428	18	4	285	6470	250	70	2560x2870x1568

HB 660R

LCS
LAS



HB660R E4

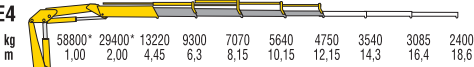

HB660R E6

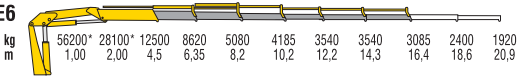

CE	<input checked="" type="checkbox"/>
NO CE	<input checked="" type="checkbox"/>
MANUAL	<input checked="" type="checkbox"/>
RADIO	<input checked="" type="checkbox"/>

*) Theoretical lifting capacity

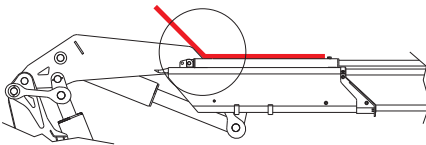

Second boom with negative angle in order to simplify operations in difficult access conditions

MODELS	LIFTING MOMENT	MAX VERTICAL REACH (HYDR)	SLEWING ANGLE	SLEWING TIME	MAX WORKING HEEL	WORKING PRESSURE	CRANE WEIGHT WITHOUT STABILIZERS	OIL TANK CAPACITY	OIL FLOW	DIMENSIONS
	tm	m	°	s/180°	°	bar	kg	l	l/min	mm B x h x S
HB660R E4	58,8	16,3	428	18	4	300	5150	250	70	2550x2420x1465
HB660R E6	-	20,5	428	18	4	300	5650	250	70	2550x2420x1465

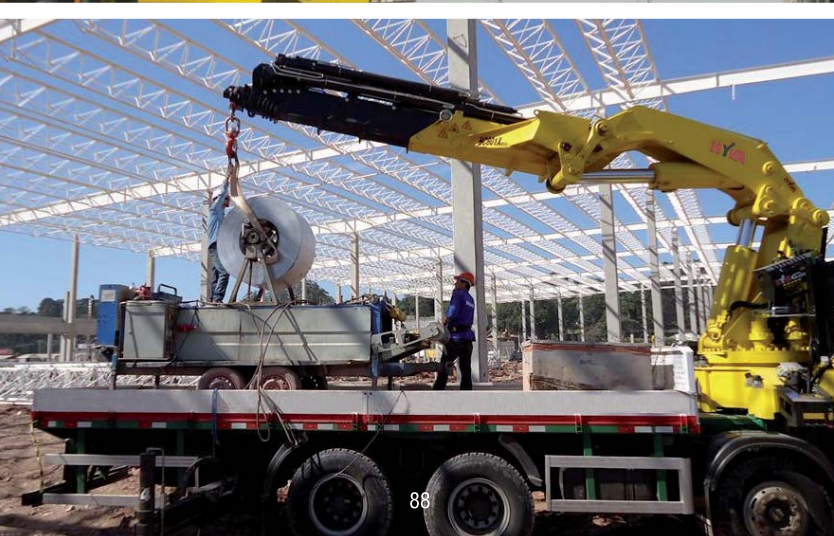
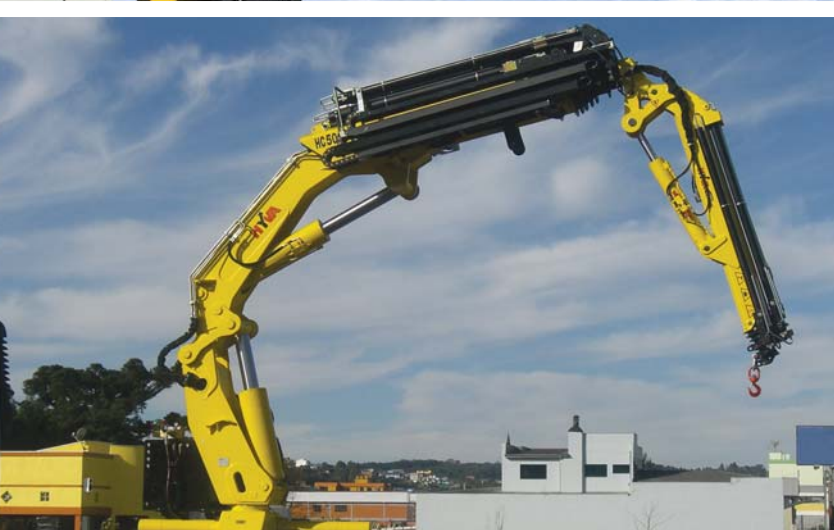

HC

HC 91	HC 223
HC 91K	HC 231 
HC 95	HC 235e 
HC 103 	HC 243
HC 111	HC 243K
HC 111K	HC 245
HC 121	HC 261 
HC 125 	HC 265e 
HC 131	HC 291
HC 131K	HC 331
HC 143	HC 361
HC 153 	HC 501 
HC 161	HC 601e 
HC 161K	HC 661e 
HC 173	HC 801 
HC 183 	HC 951 
HC 213	HC 1151 
HC 213K	HC 1651 

Best in class articulated cranes.
 For heavy users who require ultimate precision and lifting capacity.
 Packed with innovation, the HC line offers a wide range of accessories besides the already standard incorporated features

HC 91



HC91 E1

kg	8340*	2000	1400
m	1,00	4,17	5,98

HC91 E2

kg	3900*	1935	1330	1015	720	515
m	1,00	4,17	5,98	7,79	9,82	11,85

HC91 E3

kg	7630*	1795	1210	910	720	515	355
m	1,00	4,25	6,06	7,87	9,82	11,85	14,00

HC91 E4

kg	7380*	1705	1130	830	640	515	355	280
m	1,00	4,33	6,14	7,95	9,90	11,85	14,00	16,18

HC91 E5

kg	7040*	1600	1040	710	535	430	355	280
m	1,00	4,40	6,21	8,02	9,97	11,92	14,00	16,18

CE	<input checked="" type="checkbox"/>
NO CE	<input checked="" type="checkbox"/>
MANUAL	<input checked="" type="checkbox"/>
RADIO	<input checked="" type="checkbox"/>

*) Theoretical lifting capacity

HC 91



EES Extra Extension Speed
SDS Smooth Descent System
LAS Liftrod Articulating System

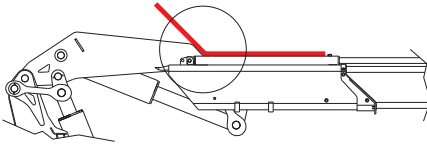

Second boom with negative angle in order to simplify operations in difficult access conditions

MODELS	LIFTING MOMENT	MAX VERTICAL REACH (HYDR)	SLEWING ANGLE	SLEWING TIME	MAX WORKING HEEL	WORKING PRESSURE	CRANE WEIGHT WITHOUT STABILIZERS	OIL TANK CAPACITY	OIL FLOW	DIMENSIONS
	tm	m	°	s/180°	°	bar	kg	l	l/min	mm B x h x S
HC91 E1	8,4	9,3	425	20	4	315	1105	75	40	2290X2085X840
HC91 E2	-	10,9	425	20	4	315	1195	75	40	2290X2085X840
HC91 E3	-	13,1	425	20	4	315	1285	75	40	2290X2085X840
HC91 E4	-	15,1	425	20	4	315	1370	75	40	2290X2085X840
HC91 E5	-	17,3	425	20	4	315	1445	75	40	2290X2085X885

HC 91 K

EES
SDS
LAS



HC91K E2

kg	8290*	2390	1700	1210
m	1,00	3,47	4,91	6,72

HC91K E3

kg	8040*	2265	1555	1115	850
m	1,00	3,55	5,00	6,80	8,75

*) Theoretical lifting capacity

CE	<input checked="" type="checkbox"/>
NO CE	<input checked="" type="checkbox"/>
MANUAL	<input checked="" type="checkbox"/>
RADIO	<input checked="" type="checkbox"/>

HC 91K



EES Extra Extension Speed
SDS Smooth Descent System
LAS Liftrod Articulating System

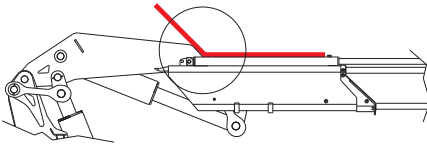

Second boom with negative angle in order to simplify operations in difficult access conditions

MODELS	LIFTING MOMENT	MAX VERTICAL REACH (HYDR)	SLEWING ANGLE	SLEWING TIME	MAX WORKING HEEL	WORKING PRESSURE	CRANE WEIGHT WITHOUT STABILIZERS	OIL TANK CAPACITY	OIL FLOW	DIMENSIONS
	tm	m	°	s/180°	°	bar	kg	l	l/min	mm B x h x S
HC91K E2	8,3	10,1	425	20	4	315	1170	75	40	2285x2085x840
HC91K E3	-	12,2	425	20	4	315	1260	75	40	2285x2085x840

HC 95



- EES**
- SDS**
- LCS**
- LAS**

HC95 E1

kg	8860*	2125	1490
m	1,00	4,17	5,98

HC95 E2

kg	8570*	2055	1415	1080	765	565
m	1,00	4,17	5,98	7,79	9,82	11,85

HC95 E3

kg	8330*	1960	1320	990	785	580	400
m	1,00	4,25	6,06	7,87	9,82	11,85	14,00

HC95 E4

kg	8010*	1850	1220	895	690	560	400	335
m	1,00	4,33	6,14	7,95	9,90	11,85	14,00	16,18

HC95 E5

kg	7480*	1700	1100	790	595	475	395	310
m	1,00	4,40	6,21	8,02	9,97	11,92	14,00	16,18

- CE**
- NO CE**
- MANUAL**
- RADIO**

*) Theoretical lifting capacity

HC 95



EES Extra Extension Speed

SDS Smooth Descent System

LCS Lift Control System

LAS Liftrod Articulating System

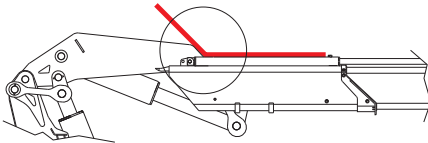

Second boom with negative angle in order to simplify operations in difficult access conditions

MODELS	LIFTING MOMENT	MAX VERTICAL REACH (HYDR)	SLEWING ANGLE	SLEWING TIME	MAX WORKING HEEL	WORKING PRESSURE	CRANE WEIGHT WITHOUT STABILIZERS	OIL TANK CAPACITY	OIL FLOW	DIMENSIONS
	tm	m	°	s/180°	°	bar	kg	l	l/min	mm B x h x S
HC95 E1	8,9	9,3	425	20	4	335	1105	75	40	2290X2085X840
HC95 E2	-	10,9	425	20	4	335	1195	75	40	2290X2085X840
HC95 E3	-	13,1	425	20	4	335	1285	75	40	2290X2085X840
HC95 E4	-	15,1	425	20	4	330	1370	75	40	2290X2085X840
HC95 E5	-	17,3	425	20	4	327	1445	75	40	2290X2085X885

HC 103



HC103 E1

kg	9020*	2260	1590
m	1,00	4,17	5,98

HC103 E2

kg	9132*	2190	1520	1160	820	605
m	1,00	4,17	5,98	7,79	9,82	11,85

HC103 E3

kg	8650*	2035	1375	1030	815	610	430
m	1,00	4,25	6,06	7,87	9,82	11,85	14,00

HC103 E4

kg	8105*	1885	1245	910	705	580	425	355
m	1,00	4,33	6,14	7,95	9,90	11,85	14,00	16,18

HC103 E5

kg	7766*	1765	1150	825	625	500	415	330
m	1,00	4,40	6,21	8,02	9,97	11,92	14,00	16,18

*) Theoretical lifting capacity

CE	<input checked="" type="checkbox"/>
NO CE	<input checked="" type="checkbox"/>
MANUAL	<input type="checkbox"/>
RADIO	<input checked="" type="checkbox"/>

HC 103 X



- EES Extra Extension Speed**
- SDS Smooth Descent System**
- P-LCS Proportional Lift Control System**
- LAS Liftrod Articulating System**

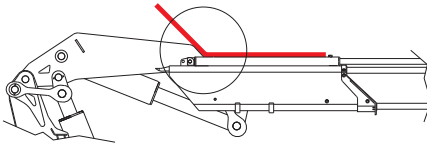

Second boom with negative angle in order to simplify operations in difficult access conditions

MODELS	LIFTING MOMENT	MAX VERTICAL REACH (HYDR)	SLEWING ANGLE	SLEWING TIME	MAX WORKING HEEL	WORKING PRESSURE	CRANE WEIGHT WITHOUT STABILIZERS	OIL TANK CAPACITY	OIL FLOW	DIMENSIONS mm B x h x S
	tm	m	°	s/180°	°	bar	kg	l	l/min	
HC103 E1	9,5	9,3	425	20	4	350	1105	75	40	2290X2085X840
HC103 E2	-	10,9	425	20	4	350	1195	75	40	2290X2085X840
HC103 E3	-	13,1	425	20	4	347	1285	75	40	2290X2085X840
HC103 E4	-	15,1	425	20	4	340	1370	75	40	2290X2085X840
HC103 E5	-	17,3	425	20	4	336	1445	75	40	2290X2085X885

HC 111

EES
SDS
LAS



HC111 E1

kg	10215*	2450	1705
m	1,00	4,17	5,98

HC111 E2

kg	9880*	2370	1620	1225	880	640
m	1,00	4,17	5,98	7,79	9,82	11,85

HC111 E3

kg	9435*	2220	1490	1110	880	640	460
m	1,00	4,25	6,06	7,87	9,82	11,85	14,00

HC111 E4

kg	9045*	2090	1375	1005	780	640	460	370
m	1,00	4,33	6,14	7,95	9,90	11,85	14,00	16,19

HC111 E5

kg	8755*	1990	1290	925	695	560	465	370
m	1,00	4,40	6,21	8,02	9,97	11,92	14,00	16,19

- CE**
- NO CE**
- MANUAL**
- RADIO**

*) Theoretical lifting capacity

HC 111

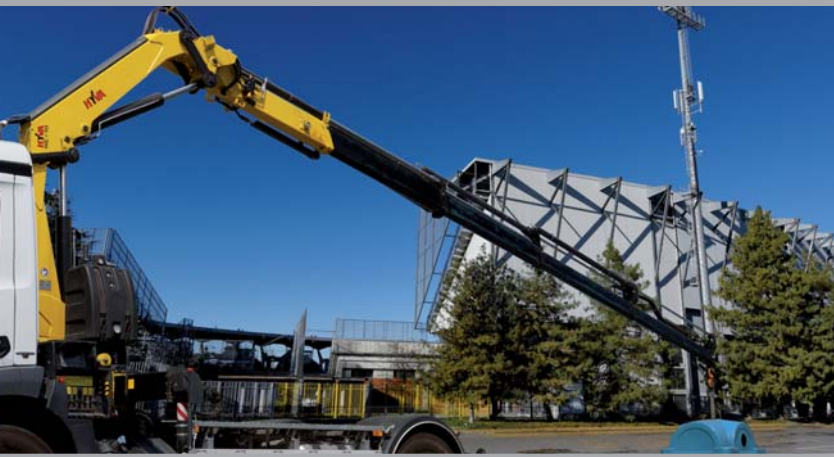

EES Extra Extension Speed
SDS Smooth Descent System
LAS Liftrod Articulating System

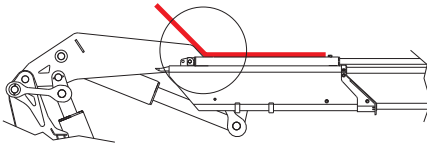

Second boom with negative angle in order to simplify operations in difficult access conditions

MODELS	LIFTING MOMENT	MAX VERTICAL REACH (HYDR)	SLEWING ANGLE	SLEWING TIME	MAX WORKING HEEL	WORKING PRESSURE	CRANE WEIGHT WITHOUT STABILIZERS	OIL TANK CAPACITY	OIL FLOW	DIMENSIONS mm B x h x S
	tm	m	°	s/180°	°	bar	kg	l	l/min	
HC111 E1	10,2	9,5	425	20	4	315	1155	75	40	2280X2110X840
HC111 E2	-	11,3	425	20	4	315	1265	75	40	2280X2110X840
HC111 E3	-	13,3	425	20	4	315	1370	75	40	2280X2110X840
HC111 E4	-	15,4	425	20	4	315	1465	75	40	2280X2110X840
HC111 E5	-	17,5	425	20	4	315	1555	75	40	2280X2110X885

HC 111K



EES
SDS
LAS

HC111K E2

kg	9590*	2665	1875	1370
m	1,00	3,60	5,04	6,85

HC111K E3

kg	9285*	2530	1760	1265	975
m	1,00	3,67	5,11	6,92	8,87

CE	<input checked="" type="checkbox"/>
NO CE	<input checked="" type="checkbox"/>
MANUAL	<input checked="" type="checkbox"/>
RADIO	<input checked="" type="checkbox"/>

*) Theoretical lifting capacity

HC 111K



EES Extra Extension Speed
SDS Smooth Descent System
LAS Liftrod Articulating System

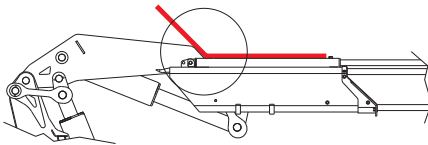

Second boom with negative angle in order to simplify operations in difficult access conditions

MODELS	LIFTING MOMENT	MAX VERTICAL REACH (HYDR)	SLEWING ANGLE	SLEWING TIME	MAX WORKING HEEL	WORKING PRESSURE	CRANE WEIGHT WITHOUT STABILIZERS	OIL TANK CAPACITY	OIL FLOW	DIMENSIONS
	tm	m	°	s/180°	°	bar	kg	l	l/min	mm B x h x S
HC111K E2	9,5	10,3	425	20	4	300	1230	75	40	2305x2110x840
HC111K E3	-	12,4	425	20	4	300	1340	75	40	2305x2110x840

HC 121

- EES**
- SDS**
- LCS**
- LAS**



HC121 E1

kg	10800*	2590	1800
m	1,00	4,17	5,98

HC121 E2

kg	10465*	2510	1710	1305	955	695
m	1,00	4,17	5,98	7,79	9,82	11,85

HC121 E3

kg	10155*	2390	1610	1205	955	695	500
m	1,00	4,25	6,06	7,87	9,82	11,85	14,00

HC121 E4

kg	9675*	2235	1480	1090	845	695	500	405
m	1,00	4,33	6,14	7,95	9,90	11,85	14,00	16,19

HC121 E5

kg	9215*	2095	1365	985	745	600	500	405
m	1,00	4,40	6,21	8,02	9,97	11,92	14,00	16,19

- CE**
- NO CE**
- MANUAL**
- RADIO**

*) Theoretical lifting capacity

HC 121



- EES** Extra Extension Speed
- SDS** Smooth Descent System
- LCS** Lift Control System
- LAS** Liftrod Articulating System

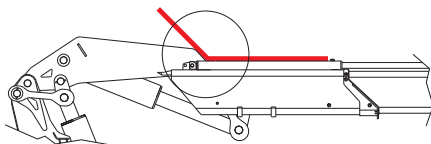

Second boom with negative angle in order to simplify operations in difficult access conditions

MODELS	LIFTING MOMENT	MAX VERTICAL REACH (HYDR)	SLEWING ANGLE	SLEWING TIME	MAX WORKING HEEL	WORKING PRESSURE	CRANE WEIGHT WITHOUT STABILIZERS	OIL TANK CAPACITY	OIL FLOW	DIMENSIONS
	tm	m	°	s/180°	°	bar	kg	l	l/min	
HC121 E1	10,8	9,5	425	20	4	335	1155	75	40	2305X2110X840
HC121 E2	-	11,3	425	20	4	335	1265	75	40	2305X2110X840
HC121 E3	-	13,3	425	20	4	335	1370	75	40	2305X2110X840
HC121 E4	-	15,4	425	20	4	330	1465	75	40	2305X2110X840
HC121 E5	-	17,5	425	20	4	330	1555	75	40	2305X2110X885

HC 125



- EES**
- SDS**
- P-LCS**
- LAS**

HC125 E1

kg	11505*	2760	1920
m	1,00	4,17	5,98

HC125 E2

kg	11175*	2680	1830	1395	995	715
m	1,00	4,17	5,98	7,79	9,82	11,85

HC125 E3

kg	10580*	2490	1680	1260	995	715	525
m	1,00	4,25	6,06	7,87	9,82	11,85	14,00

HC125 E4

kg	9935*	2295	1525	1120	870	715	525	430
m	1,00	4,33	6,14	7,95	9,90	11,85	14,00	16,19

HC125 E5

kg	9570*	2175	1425	1030	780	630	525	430
m	1,00	4,40	6,21	8,02	9,97	11,92	14,00	16,19

- CE**
- NO CE**
- MANUAL**
- RADIO**

*) Theoretical lifting capacity

HC 125



- EES** Extra Extension Speed
- SDS** Smooth Descent System
- P-LCS** Proportional Lift Control System
- LAS** Liftrod Articulating System

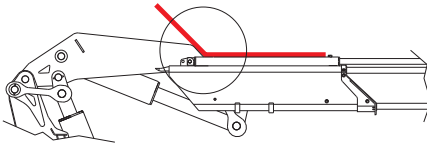

Second boom with negative angle in order to simplify operations in difficult access conditions

MODELS	LIFTING MOMENT	MAX VERTICAL REACH (HYDR)	SLEWING ANGLE	SLEWING TIME	MAX WORKING HEEL	WORKING PRESSURE	CRANE WEIGHT WITHOUT STABILIZERS	OIL TANK CAPACITY	OIL FLOW	DIMENSIONS mm B x h x S
	tm	m	°	s/180°	°	bar	kg	l	l/min	
HC125 E1	11,5	9,5	425	20	4	350	1155	75	40	2305X2110X840
HC125 E2	-	11,3	425	20	4	350	1265	75	40	2305X2110X840
HC125 E3	-	13,3	425	20	4	345	1370	75	40	2305X2110X840
HC125 E4	-	15,4	425	20	4	340	1465	75	40	2305X2110X840
HC125 E5	-	17,5	425	20	4	340	1555	75	40	2305X2110X885

HC 131

EES
SDS
LAS



HC131 E2

kg	12010*	2595	1770	1345	975	720	525
m	1,00	4,63	6,58	8,53	10,91	12,96	15,11

HC131 E3

kg	11610*	2465	1650	1230	975	720	525	375
m	1,00	4,71	6,66	8,61	10,66	12,96	15,11	17,26

HC131 E4

kg	11230*	2340	1540	1125	870	720	525	375	280
m	1,00	4,80	6,75	8,70	10,75	12,80	15,11	17,26	19,36

HC131 E5

kg	10860*	2225	1435	1025	775	625	525	375	280
m	1,00	4,88	6,83	8,78	10,83	12,88	15,03	17,26	19,36

HC131 E6

kg	10520*	2120	1345	935	690	535	435	375	280
m	1,00	4,96	6,91	8,86	10,91	12,96	15,11	17,26	19,36

HC131 E3J2

kg					430	380	340	260
m					13,35	14,75	16,22	17,80

HC131 E4J2

kg						250	220	200	130
m						15,50	16,85	18,35	19,89

- CE**
- NO CE**
- MANUAL**
- RADIO**

*) Theoretical lifting capacity

HC 131



EES Extra Extension Speed
SDS Smooth Descent System
LAS Liftrod Articulating System

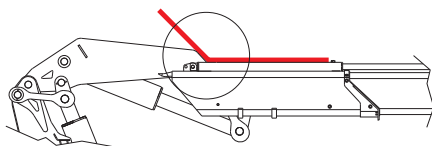

Second boom with negative angle in order to simplify operations in difficult access conditions

MODELS	LIFTING MOMENT	MAX VERTICAL REACH (HYDR)	SLEWING ANGLE	SLEWING TIME	MAX WORKING HEEL	WORKING PRESSURE	CRANE WEIGHT WITHOUT STABILIZERS	OIL TANK CAPACITY	OIL FLOW	DIMENSIONS mm B x h x S
	tm	m	°	s/180°	°	bar	kg	l	l/min	
HC131 E2	12,0	12,2	425	20	4	290	1610	130	60	2450x2330x825
HC131 E3	-	14,4	425	20	4	290	1725	130	60	2450x2330x825
HC131 E4	-	16,5	425	20	4	290	1830	130	60	2450x2330x825
HC131 E5	-	18,8	425	20	4	290	1930	130	60	2450x2330x895
HC131 E6	-	21,0	425	20	4	290	2020	130	60	2450x2330x895
HC131 E3J2	-	19,8	425	20	3	290	2065	130	60	2450x2450x940
HC131 E4J2	-	22,0	425	20	3	290	2185	130	60	2450x2500x940

HC 131K

EES
SDS
LAS



HC131K E2

kg	12520*	3210	2310	1700
m	1,00	3,90	5,30	7,10

HC131K E3

kg	12170*	3080	2200	1600	1250
m	1,00	3,95	5,38	7,20	9,15

- CE**
- NO CE**
- MANUAL**
- RADIO**

*) Theoretical lifting capacity

HC 131K



EES Extra Extension Speed
SDS Smooth Descent System
LAS Liftrod Articulating System

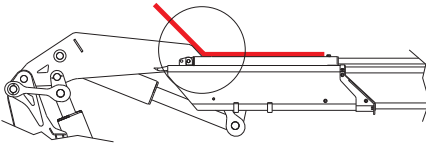

Second boom with negative angle in order to simplify operations in difficult access conditions

MODELS	LIFTING MOMENT	MAX VERTICAL REACH (HYDR)	SLEWING ANGLE	SLEWING TIME	MAX WORKING HEEL	WORKING PRESSURE	CRANE WEIGHT WITHOUT STABILIZERS	OIL TANK CAPACITY	OIL FLOW	DIMENSIONS
	tm	m	°	s/180°	°	bar	kg	l	l/min	mm B x h x S
HC131K E2	12,5	10,9	425	20	4	300	1525	130	40	2455x2330x825
HC131K E3	-	12,9	425	20	4	300	1625	130	40	2455x2330x825

HC 143

- EES**
- SDS**
- LCS**
- LAS**



HC143 E2		<table border="0"> <tr> <td>kg</td> <td>12390*</td> <td>2675</td> <td>1840</td> <td>1415</td> <td>1045</td> <td>780</td> <td>575</td> <td></td> </tr> <tr> <td>m</td> <td>1,00</td> <td>4,63</td> <td>6,58</td> <td>8,53</td> <td>10,91</td> <td>12,96</td> <td>15,11</td> <td></td> </tr> </table>	kg	12390*	2675	1840	1415	1045	780	575		m	1,00	4,63	6,58	8,53	10,91	12,96	15,11		<table border="1" style="background-color: yellow; width: 100px;"> <tr><td>CE</td><td><input checked="" type="checkbox"/></td></tr> <tr><td>NO CE</td><td><input checked="" type="checkbox"/></td></tr> <tr><td>MANUAL</td><td><input checked="" type="checkbox"/></td></tr> <tr><td>RADIO</td><td><input checked="" type="checkbox"/></td></tr> </table>	CE	<input checked="" type="checkbox"/>	NO CE	<input checked="" type="checkbox"/>	MANUAL	<input checked="" type="checkbox"/>	RADIO	<input checked="" type="checkbox"/>
kg	12390*	2675	1840	1415	1045	780	575																						
m	1,00	4,63	6,58	8,53	10,91	12,96	15,11																						
CE	<input checked="" type="checkbox"/>																												
NO CE	<input checked="" type="checkbox"/>																												
MANUAL	<input checked="" type="checkbox"/>																												
RADIO	<input checked="" type="checkbox"/>																												
HC143 E3		<table border="0"> <tr> <td>kg</td> <td>11940*</td> <td>2535</td> <td>1720</td> <td>1295</td> <td>1045</td> <td>780</td> <td>575</td> <td>420</td> </tr> <tr> <td>m</td> <td>1,00</td> <td>4,71</td> <td>6,66</td> <td>8,61</td> <td>10,66</td> <td>12,96</td> <td>15,11</td> <td>17,26</td> </tr> </table>	kg	11940*	2535	1720	1295	1045	780	575	420	m	1,00	4,71	6,66	8,61	10,66	12,96	15,11	17,26									
kg	11940*	2535	1720	1295	1045	780	575	420																					
m	1,00	4,71	6,66	8,61	10,66	12,96	15,11	17,26																					
HC143 E4		<table border="0"> <tr> <td>kg</td> <td>11570*</td> <td>2410</td> <td>1605</td> <td>1185</td> <td>930</td> <td>780</td> <td>575</td> <td>420</td> <td>320</td> </tr> <tr> <td>m</td> <td>1,00</td> <td>4,80</td> <td>6,75</td> <td>8,70</td> <td>10,75</td> <td>12,80</td> <td>15,11</td> <td>17,26</td> <td>19,36</td> </tr> </table>	kg	11570*	2410	1605	1185	930	780	575	420	320	m	1,00	4,80	6,75	8,70	10,75	12,80	15,11	17,26	19,36							
kg	11570*	2410	1605	1185	930	780	575	420	320																				
m	1,00	4,80	6,75	8,70	10,75	12,80	15,11	17,26	19,36																				
HC143 E5		<table border="0"> <tr> <td>kg</td> <td>11180*</td> <td>2290</td> <td>1500</td> <td>1080</td> <td>830</td> <td>675</td> <td>575</td> <td>420</td> <td>320</td> </tr> <tr> <td>m</td> <td>1,00</td> <td>4,88</td> <td>6,83</td> <td>8,78</td> <td>10,83</td> <td>12,88</td> <td>15,03</td> <td>17,26</td> <td>19,36</td> </tr> </table>	kg	11180*	2290	1500	1080	830	675	575	420	320	m	1,00	4,88	6,83	8,78	10,83	12,88	15,03	17,26	19,36							
kg	11180*	2290	1500	1080	830	675	575	420	320																				
m	1,00	4,88	6,83	8,78	10,83	12,88	15,03	17,26	19,36																				
HC143 E6		<table border="0"> <tr> <td>kg</td> <td>10840*</td> <td>2185</td> <td>1405</td> <td>990</td> <td>740</td> <td>585</td> <td>480</td> <td>420</td> <td>320</td> </tr> <tr> <td>m</td> <td>1,00</td> <td>4,96</td> <td>6,91</td> <td>8,86</td> <td>10,91</td> <td>12,96</td> <td>15,11</td> <td>17,26</td> <td>19,36</td> </tr> </table>	kg	10840*	2185	1405	990	740	585	480	420	320	m	1,00	4,96	6,91	8,86	10,91	12,96	15,11	17,26	19,36							
kg	10840*	2185	1405	990	740	585	480	420	320																				
m	1,00	4,96	6,91	8,86	10,91	12,96	15,11	17,26	19,36																				
HC143 E3J2		<table border="0"> <tr> <td>kg</td> <td></td> <td></td> <td></td> <td></td> <td></td> <td>465</td> <td>420</td> <td>380</td> <td>290</td> </tr> <tr> <td>m</td> <td></td> <td></td> <td></td> <td></td> <td></td> <td>13,35</td> <td>14,75</td> <td>16,22</td> <td>17,80</td> </tr> </table>	kg						465	420	380	290	m						13,35	14,75	16,22	17,80							
kg						465	420	380	290																				
m						13,35	14,75	16,22	17,80																				
HC143 E4J2		<table border="0"> <tr> <td>kg</td> <td></td> <td></td> <td></td> <td></td> <td></td> <td></td> <td>290</td> <td>250</td> <td>230</td> <td>160</td> </tr> <tr> <td>m</td> <td></td> <td></td> <td></td> <td></td> <td></td> <td></td> <td>15,50</td> <td>16,85</td> <td>18,35</td> <td>19,89</td> </tr> </table>	kg							290	250	230	160	m							15,50	16,85	18,35	19,89					
kg							290	250	230	160																			
m							15,50	16,85	18,35	19,89																			

*) Theoretical lifting capacity

HC 143



- EES** Extra Extension Speed
- SDS** Smooth Descent System
- LCS** Lift Control System
- LAS** Liftrod Articulating System

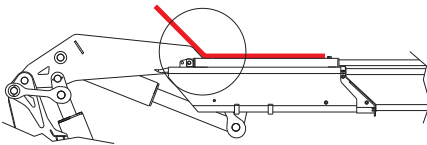

Second boom with negative angle in order to simplify operations in difficult access conditions

MODELS	LIFTING MOMENT	MAX VERTICAL REACH (HYDR)	SLEWING ANGLE	SLEWING TIME	MAX WORKING HEEL	WORKING PRESSURE	CRANE WEIGHT WITHOUT STABILIZERS	OIL TANK CAPACITY	OIL FLOW	DIMENSIONS
	tm	m	°	s/180°	°	bar	kg	l	l/min	mm B x h x S
HC143 E2	12,4	12,2	425	20	4	305	1610	130	60	2450x2330x825
HC143 E3	-	14,4	425	20	4	305	1725	130	60	2450x2330x825
HC143 E4	-	16,5	425	20	4	305	1830	130	60	2450x2330x825
HC143 E5	-	18,8	425	20	4	305	1930	130	60	2450x2330x895
HC143 E6	-	21,0	425	20	4	305	2020	130	60	2450x2330x895
HC143 E3J2	-	19,8	425	20	3	305	2065	130	60	2450x2450x940
HC143 E4J2	-	22,0	425	20	3	305	2185	130	60	2450x2500x940

HC 153

- EES**
- SDS**
- P-LCS**
- LAS**



HC153 E2

kg	13940*	3010	2060	1570	1160	870	655
m	1,00	4,63	6,58	8,53	10,91	12,96	15,11

HC153 E3

kg	13520*	2870	1940	1455	1160	870	655	485
m	1,00	4,71	6,66	8,61	10,66	12,96	15,11	17,26

HC153 E4

kg	13150*	2740	1825	1345	1050	870	655	485	395
m	1,00	4,80	6,75	8,70	10,75	12,80	15,11	17,26	19,36

HC153 E5

kg	12760*	2615	1720	1245	955	775	655	485	395
m	1,00	4,88	6,83	8,78	10,83	12,88	15,03	17,26	19,36

HC153 E6

kg	12420*	2505	1625	1155	865	685	565	485	395
m	1,00	4,96	6,91	8,86	10,91	12,96	15,11	17,26	19,36

HC153 E3J2

kg						615	560	500	350
m						13,35	14,75	16,22	17,80

HC153 E4J2

kg						420	380	340	200
m						15,50	16,85	18,35	19,89

- CE**
- NO CE**
- MANUAL**
- RADIO**

*) Theoretical lifting capacity

HC 153 X



- EES** Extra Extension Speed
- SDS** Smooth Descent System
- P-LCS** Proportional Lift Control System
- LAS** Liftrod Articulating System

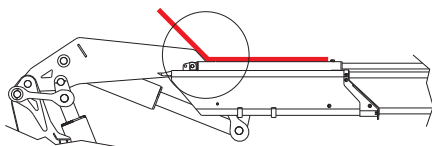

Second boom with negative angle in order to simplify operations in difficult access conditions

MODELS	LIFTING MOMENT	MAX VERTICAL REACH (HYDR)	SLEWING ANGLE	SLEWING TIME	MAX WORKING HEEL	WORKING PRESSURE	CRANE WEIGHT WITHOUT STABILIZERS	OIL TANK CAPACITY	OIL FLOW	DIMENSIONS
	tm	m	°	s/180°	°	bar	kg	l	l/min	mm B x h x S
HC153 E2	13,9	12,2	425	20	4	325	1610	130	60	2450x2330x825
HC153 E3	-	14,4	425	20	4	325	1725	130	60	2450x2330x825
HC153 E4	-	16,5	425	20	4	325	1830	130	60	2450x2330x825
HC153 E5	-	18,8	425	20	4	325	1930	130	60	2450x2330x895
HC153 E6	-	21,0	425	20	4	325	2020	130	60	2450x2330x895
HC153 E3J2	-	19,8	425	20	3	325	2065	130	60	2450x2450x940
HC153 E4J2	-	22,0	425	20	3	325	2185	130	60	2450x2500x940

HC 161



EES
SDS
LAS

HC161 E2

kg	15330*	3310	2265	1725	1270	950	710
m	1,00	4,63	6,58	8,53	10,91	12,96	15,11

HC161 E3

kg	14860*	3155	2125	1590	1270	950	710	530
m	1,00	4,71	6,66	8,61	10,66	12,96	15,11	17,26

HC161 E4

kg	14450*	3010	2000	1470	1150	950	710	530	400
m	1,00	4,80	6,75	8,70	10,75	12,80	15,11	17,26	19,36

HC161 E5

kg	14030*	2875	1885	1360	1040	845	710	530	400
m	1,00	4,88	6,83	8,78	10,83	12,88	15,03	17,26	19,36

HC161 E6

kg	13640*	2750	1780	1260	945	745	615	530	400
m	1,00	4,96	6,91	8,86	10,91	12,96	15,11	17,26	19,36

HC161 E3J3

kg					640	545	485	425	320	270
m					13,60	15,20	16,70	18,30	19,90	21,70

- CE**
- NO CE**
- MANUAL**
- RADIO**

*) Theoretical lifting capacity

HC 161



EES Extra Extension Speed
SDS Smooth Descent System
LAS Liftrod Articulating System

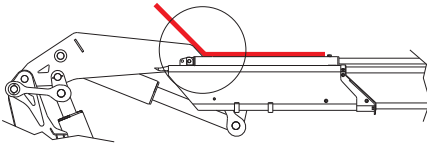

Second boom with negative angle in order to simplify operations in difficult access conditions

MODELS	LIFTING MOMENT	MAX VERTICAL REACH (HYDR)	SLEWING ANGLE	SLEWING TIME	MAX WORKING HEEL	WORKING PRESSURE	CRANE WEIGHT WITHOUT STABILIZERS	OIL TANK CAPACITY	OIL FLOW	DIMENSIONS
	tm	m	°	s/180°	°	bar	kg	l	l/min	mm B x h x S
HC161 E2	15,3	12,2	425	20	4	300	1740	130	60	2475x2330x825
HC161 E3	-	14,4	425	20	4	300	1870	130	60	2475x2330x825
HC161 E4	-	16,5	425	20	4	300	1990	130	60	2475x2330x825
HC161 E5	-	18,8	425	20	4	300	2100	130	60	2475x2330x905
HC161 E6	-	21,0	425	20	4	300	2195	130	60	2475x2330x905
HC161 E3J3	-	21,9	425	20	3	315	2360	130	60	2475x2615x957

HC 161K



HC161K E2

kg	15440*	4010	2940	2115
m	1,00	3,85	5,18	7,13

HC161K E3

kg	15050*	3860	2805	1990	1530
m	1,00	3,90	5,23	7,18	9,23

CE	<input checked="" type="checkbox"/>
NO CE	<input checked="" type="checkbox"/>
MANUAL	<input checked="" type="checkbox"/>
RADIO	<input checked="" type="checkbox"/>

*) Theoretical lifting capacity

HC 161K



- EES** Extra Extension Speed
- SDS** Smooth Descent System
- LAS** Liftrod Articulating System

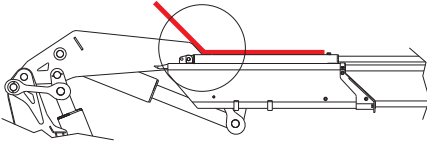

Second boom with negative angle in order to simplify operations in difficult access conditions

MODELS	LIFTING MOMENT	MAX VERTICAL REACH (HYDR)	SLEWING ANGLE	SLEWING TIME	MAX WORKING HEEL	WORKING PRESSURE	CRANE WEIGHT WITHOUT STABILIZERS	OIL TANK CAPACITY	OIL FLOW	DIMENSIONS
	tm	m	°	s/180°	°	bar	kg	l	l/min	mm B x h x S
HC161K E2	15,4	10,9	425	20	4	300	1630	130	60	2470x2330x825
HC161K E3	-	12,9	425	20	4	300	1755	130	60	2470x2330x825

HC 173

- EES**
- SDS**
- LCS**
- LAS**



HC173 E2

kg	15720*	3395	2345	1810	1350	1025	780
m	1,00	4,63	6,58	8,53	10,91	12,96	15,11

HC173 E3

kg	15260*	3240	2205	1670	1350	1025	780	585
m	1,00	4,71	6,66	8,61	10,66	12,96	15,11	17,26

HC173 E4

kg	14830*	3090	2075	1545	1225	1025	780	585	450
m	1,00	4,80	6,75	8,70	10,75	12,80	15,11	17,26	19,36

HC173 E5

kg	14420*	2955	1955	1430	1110	910	780	585	450
m	1,00	4,88	6,83	8,78	10,83	12,88	15,03	17,26	19,36

HC173 E6

kg	14040*	2830	1845	1325	1005	805	675	585	450
m	1,00	4,96	6,91	8,86	10,91	12,96	15,11	17,26	19,36

HC173 E3J3

kg						700	605	560	475	370	310
m						13,60	15,20	16,70	18,30	19,90	21,70

- CE**
- NO CE**
- MANUAL**
- RADIO**

*) Theoretical lifting capacity

HC 173



- EES** Extra Extension Speed
- SDS** Smooth Descent System
- LCS** Lift Control System
- LAS** Liftród Articulating System

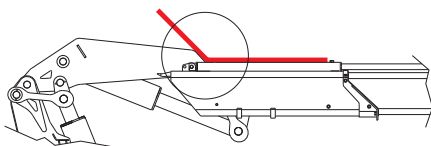







Second boom with negative angle in order to simplify operations in difficult access conditions

MODELS	LIFTING MOMENT	MAX VERTICAL REACH (HYDR)	SLEWING ANGLE	SLEWING TIME	MAX WORKING HEEL	WORKING PRESSURE	CRANE WEIGHT WITHOUT STABILIZERS	OIL TANK CAPACITY	OIL FLOW	DIMENSIONS
	tm	m	°	s/180°	°	bar	kg	l	l/min	mm B x h x S
HC173 E2	15,7	12,2	425	20	4	310	1745	130	60	2475x2330x825
HC173 E3	-	14,4	425	20	4	310	1875	130	60	2475x2330x825
HC173 E4	-	16,5	425	20	4	310	1995	130	60	2475x2330x825
HC173 E5	-	18,8	425	20	4	310	2105	130	60	2475x2330x905
HC173 E6	-	21,0	425	20	4	310	2200	130	60	2475x2330x905
HC173 E3J3	-	21,9	425	20	3	330	2365	130	60	2475x2615x957

HC 183

- EES**
- SDS**
- P-LCS**
- LAS**



HC183 E2		<table border="1"> <tr> <td>kg</td> <td>17290*</td> <td>3735</td> <td>2560</td> <td>1955</td> <td>1455</td> <td>1105</td> <td>845</td> <td></td> <td></td> </tr> <tr> <td>m</td> <td>1,00</td> <td>4,63</td> <td>6,58</td> <td>8,53</td> <td>10,91</td> <td>12,96</td> <td>15,11</td> <td></td> <td></td> </tr> </table>	kg	17290*	3735	2560	1955	1455	1105	845			m	1,00	4,63	6,58	8,53	10,91	12,96	15,11			<table border="1"> <tr> <td>CE</td> <td><input checked="" type="checkbox"/></td> </tr> <tr> <td>NO CE</td> <td><input checked="" type="checkbox"/></td> </tr> <tr> <td>MANUAL</td> <td><input type="checkbox"/></td> </tr> <tr> <td>RADIO</td> <td><input checked="" type="checkbox"/></td> </tr> </table>	CE	<input checked="" type="checkbox"/>	NO CE	<input checked="" type="checkbox"/>	MANUAL	<input type="checkbox"/>	RADIO	<input checked="" type="checkbox"/>
kg	17290*	3735	2560	1955	1455	1105	845																								
m	1,00	4,63	6,58	8,53	10,91	12,96	15,11																								
CE	<input checked="" type="checkbox"/>																														
NO CE	<input checked="" type="checkbox"/>																														
MANUAL	<input type="checkbox"/>																														
RADIO	<input checked="" type="checkbox"/>																														
HC183 E3		<table border="1"> <tr> <td>kg</td> <td>16810*</td> <td>3570</td> <td>2420</td> <td>1820</td> <td>1455</td> <td>1105</td> <td>845</td> <td>645</td> </tr> <tr> <td>m</td> <td>1,00</td> <td>4,71</td> <td>6,66</td> <td>8,61</td> <td>10,66</td> <td>12,96</td> <td>15,11</td> <td>17,26</td> </tr> </table>	kg	16810*	3570	2420	1820	1455	1105	845	645	m	1,00	4,71	6,66	8,61	10,66	12,96	15,11	17,26											
kg	16810*	3570	2420	1820	1455	1105	845	645																							
m	1,00	4,71	6,66	8,61	10,66	12,96	15,11	17,26																							
HC183 E4		<table border="1"> <tr> <td>kg</td> <td>16390*</td> <td>3415</td> <td>2290</td> <td>1700</td> <td>1335</td> <td>1105</td> <td>845</td> <td>645</td> <td>510</td> </tr> <tr> <td>m</td> <td>1,00</td> <td>4,80</td> <td>6,75</td> <td>8,70</td> <td>10,75</td> <td>12,80</td> <td>15,11</td> <td>17,26</td> <td>19,36</td> </tr> </table>	kg	16390*	3415	2290	1700	1335	1105	845	645	510	m	1,00	4,80	6,75	8,70	10,75	12,80	15,11	17,26	19,36									
kg	16390*	3415	2290	1700	1335	1105	845	645	510																						
m	1,00	4,80	6,75	8,70	10,75	12,80	15,11	17,26	19,36																						
HC183 E5		<table border="1"> <tr> <td>kg</td> <td>15980*</td> <td>3275</td> <td>2170</td> <td>1585</td> <td>1225</td> <td>995</td> <td>845</td> <td>645</td> <td>510</td> </tr> <tr> <td>m</td> <td>1,00</td> <td>4,88</td> <td>6,83</td> <td>8,78</td> <td>10,83</td> <td>12,88</td> <td>15,03</td> <td>17,26</td> <td>19,36</td> </tr> </table>	kg	15980*	3275	2170	1585	1225	995	845	645	510	m	1,00	4,88	6,83	8,78	10,83	12,88	15,03	17,26	19,36									
kg	15980*	3275	2170	1585	1225	995	845	645	510																						
m	1,00	4,88	6,83	8,78	10,83	12,88	15,03	17,26	19,36																						
HC183 E6		<table border="1"> <tr> <td>kg</td> <td>15600*</td> <td>3145</td> <td>2065</td> <td>1485</td> <td>1125</td> <td>900</td> <td>745</td> <td>645</td> <td>510</td> </tr> <tr> <td>m</td> <td>1,00</td> <td>4,96</td> <td>6,91</td> <td>8,86</td> <td>10,91</td> <td>12,96</td> <td>15,11</td> <td>17,26</td> <td>19,36</td> </tr> </table>	kg	15600*	3145	2065	1485	1125	900	745	645	510	m	1,00	4,96	6,91	8,86	10,91	12,96	15,11	17,26	19,36									
kg	15600*	3145	2065	1485	1125	900	745	645	510																						
m	1,00	4,96	6,91	8,86	10,91	12,96	15,11	17,26	19,36																						
HC183 E3J3		<table border="1"> <tr> <td>kg</td> <td></td> <td></td> <td></td> <td></td> <td></td> <td>730</td> <td>645</td> <td>575</td> <td>505</td> <td>400</td> <td>340</td> </tr> <tr> <td>m</td> <td></td> <td></td> <td></td> <td></td> <td></td> <td>13,60</td> <td>15,20</td> <td>16,70</td> <td>18,30</td> <td>19,90</td> <td>21,70</td> </tr> </table>	kg						730	645	575	505	400	340	m						13,60	15,20	16,70	18,30	19,90	21,70					
kg						730	645	575	505	400	340																				
m						13,60	15,20	16,70	18,30	19,90	21,70																				

*) Theoretical lifting capacity

HC 183



- EES** Extra Extension Speed
- SDS** Smooth Descent System
- P-LCS** Proportional Lift Control System
- LAS** Liftrod Articulating System

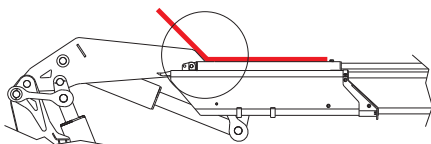

Second boom with negative angle in order to simplify operations in difficult access conditions

MODELS	LIFTING MOMENT	MAX VERTICAL REACH (HYDR)	SLEWING ANGLE	SLEWING TIME	MAX WORKING HEEL	WORKING PRESSURE	CRANE WEIGHT WITHOUT STABILIZERS	OIL TANK CAPACITY	OIL FLOW	DIMENSIONS
	tm	m	°	s/180°	°	bar	kg	l	l/min	mm B x h x S
HC183 E2	17,3	12,2	425	20	4	330	1745	130	60	2475x2330x825
HC183 E3	-	14,4	425	20	4	330	1875	130	60	2475x2330x825
HC183 E4	-	16,5	425	20	4	330	1995	130	60	2475x2330x825
HC183 E5	-	18,8	425	20	4	330	2105	130	60	2475x2330x905
HC183 E6	-	21,0	425	20	4	330	2200	130	60	2475x2330x905
HC183 E3J3	-	21,9	425	20	3	340	2365	130	60	2475x2615x957

HC 213

EES
SDS
LAS



HC213 E2

kg	19810*	4555	3075	2325
m	1,00	4,35	6,32	8,29

HC213 E3

kg	18745*	4310	2840	2120	1670	1115	940	725
m	1,00	4,35	6,32	8,29	10,36	12,51	14,73	17,01

HC213 E4

kg	18160*	4100	2685	1960	1525	1255	940	725	600
m	1,00	4,43	6,40	8,37	10,44	12,51	14,72	17,01	19,11

HC213 E5

kg	17585*	3900	2525	1815	1385	1120	945	725	600
m	1,00	4,51	6,48	8,45	10,52	12,59	14,72	17,01	19,11

HC213 E6

kg	17225*	3745	2405	1810	1345	1050	845	730	600
m	1,00	4,60	6,57	8,54	10,61	12,68	14,81	17,01	19,11

HC213 E3J3

kg					710	600	520	465
m					13,36	15,06	16,81	18,56

HC213 E4J3

kg						575	505	450	410
m						15,43	16,99	18,55	20,11

HC213 E5J2

kg							525	480	445
m							17,41	18,79	20,27

- CE**
- NO CE**
- MANUAL**
- RADIO**

*) Theoretical lifting capacity

HC 213



EES Extra Extension Speed
SDS Smooth Descent System
LAS Liftrod Articulating System

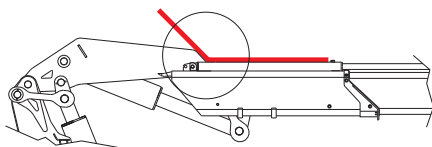

Second boom with negative angle in order to simplify operations in difficult access conditions

MODELS	LIFTING MOMENT	MAX VERTICAL REACH (HYDR)	SLEWING ANGLE	SLEWING TIME	MAX WORKING HEEL	WORKING PRESSURE	CRANE WEIGHT WITHOUT STABILIZERS	OIL TANK CAPACITY	OIL FLOW	DIMENSIONS
	tm	m	°	s/180°	°	bar	kg	l	l/min	mm B x h x S
HC213 E2	19,8	12,0	415	20	4	320	2210	130	70	2520x2300x930
HC213 E3	-	14,1	415	20	4	310	2360	130	70	2520x2300x930
HC213 E4	-	16,2	415	20	4	310	2510	130	70	2520x2300x930
HC213 E5	-	18,4	415	20	4	310	2630	130	70	2520x2300x930
HC213 E6	-	20,7	415	20	4	310	2725	130	70	2520x2300x930
HC213 E3J3	-	22,2	415	20	3	-	3020	130	70	2520x2695x1050
HC213 E4J3	-	23,8	415	20	3	-	3000	130	70	2520x2600x1050
HC213 E5J2	-	23,9	415	20	3	-	2905	130	70	2520x2550x1050

HC 213K

EES
SDS
LAS



HC213K E2

kg	18690*	5280	3815	2715
m	1,00	3,54	4,87	6,82

HC213K E3

kg	17675*	4870	3380	2455	1880
m	1,00	3,63	4,96	6,91	8,96

HC213K E4

kg	17315*	4680	3340	2320	1750	1410
m	1,00	3,70	5,03	6,98	9,03	11,08

*) Theoretical lifting capacity

CE	<input checked="" type="checkbox"/>
NO CE	<input checked="" type="checkbox"/>
MANUAL	<input checked="" type="checkbox"/>
RADIO	<input checked="" type="checkbox"/>

HC 213K



EES Extra Extension Speed
SDS Smooth Descent System
LAS Liftrod Articulating System

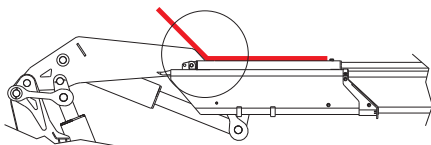

Second boom with negative angle in order to simplify operations in difficult access conditions

MODELS	LIFTING MOMENT	MAX VERTICAL REACH (HYDR)	SLEWING ANGLE	SLEWING TIME	MAX WORKING HEEL	WORKING PRESSURE	CRANE WEIGHT WITHOUT STABILIZERS	OIL TANK CAPACITY	OIL FLOW	DIMENSIONS mm B x h x S
	tm	m	°	s/180°	°	bar	kg	l	l/min	
HC213K E2	18,7	10,5	415	20	4	300	2085	130	70	2520x2300x870
HC213K E3	-	12,7	415	20	4	300	2220	130	70	2520x2300x870
HC213K E4	-	14,8	415	20	4	300	2340	130	70	2520x2300x870

HC 223

- EES**
- SDS**
- LCS**
- LAS**



HC223 E2

kg	20705*	4760	3245	2475
m	1,00	4,35	6,32	8,29

HC223 E3

kg	20180*	4640	3110	2310	1870	1240	1065	725
m	1,00	4,35	6,32	8,29	10,36	12,51	14,73	17,01

HC223 E4

kg	19580*	4420	2970	2140	1700	1395	1065	835	600
m	1,00	4,43	6,40	8,37	10,44	12,51	14,72	17,01	19,11

HC223 E5

kg	19300*	4280	2730	2020	1545	1250	1070	840	705
m	1,00	4,51	6,48	8,45	10,52	12,59	14,72	17,01	19,11

HC223 E6

kg	18860*	4100	2615	1910	1485	1180	1000	840	705
m	1,00	4,60	6,57	8,54	10,61	12,68	14,81	17,01	19,11

HC223 E3J3

kg					775	660	580	525
m					13,36	15,06	16,81	18,56

HC223 E4J3

kg						635	565	510	470
m						15,43	16,99	18,55	20,11

HC223 E5J2

kg							590	540	510
m							17,41	18,79	20,27

- CE**
- NO CE**
- MANUAL**
- RADIO**

*) Theoretical lifting capacity

HC 223



- EES** Extra Extension Speed
- SDS** Smooth Descent System
- LCS** Lift Control System
- LAS** Liftrod Articulating System

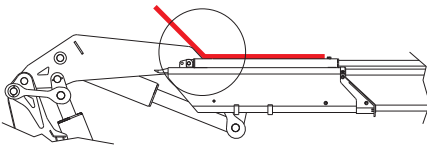

Second boom with negative angle in order to simplify operations in difficult access conditions

MODELS	LIFTING MOMENT	MAX VERTICAL REACH (HYDR)	SLEWING ANGLE	SLEWING TIME	MAX WORKING HEEL	WORKING PRESSURE	CRANE WEIGHT WITHOUT STABILIZERS	OIL TANK CAPACITY	OIL FLOW	DIMENSIONS mm B x h x S
	tm	m	°	s/180°	°	bar	kg	l	l/min	
HC223 E2	20,7	12,0	415	20	4	335	2210	130	70	2520x2300x930
HC223 E3	-	14,1	415	20	4	335	2360	130	70	2520x2300x930
HC223 E4	-	16,2	415	20	4	335	2510	130	70	2520x2300x930
HC223 E5	-	18,4	415	20	4	335	2630	130	70	2520x2300x930
HC223 E6	-	20,7	415	20	4	335	2725	130	70	2520x2300x930
HC223 E3J3	-	22,2	415	20	3	-	3020	130	70	2520x2695x1050
HC223 E4J3	-	23,8	415	20	3	-	3000	130	70	2520x2600x1050
HC223 E5J2	-	23,9	415	20	3	-	2905	130	70	2520x2550x1050

HC 231

- EES**
- SDS**
- P-LCS**
- LAS**



HC231 E2

kg	21705*	4990	3380	2560
m	1,00	4,35	6,32	8,29

HC231 E3

kg	21160*	4865	3245	2420	1915	1460	1130	725
m	1,00	4,35	6,32	8,29	10,36	12,51	14,73	17,14

HC231 E4

kg	20710*	4675	3085	2270	1770	1460	1130	890	600
m	1,00	4,43	6,40	8,37	10,44	12,51	14,73	17,01	19,11

HC231 E5

kg	20270*	4495	2940	2140	1640	1340	1130	890	755
m	1,00	4,51	6,48	8,45	10,52	12,59	14,72	17,01	19,11

HC231 E6

kg	19985*	4345	2830	2040	1550	1280	1060	895	755
m	1,00	4,60	6,57	8,54	10,61	12,68	14,81	17,01	19,11

HC231 E3J3

kg					905	775	675	605
m					13,36	15,06	16,81	18,56

HC231 E4J3

kg						715	635	570	520
m						15,43	16,99	18,55	20,11

HC231 E5J2

kg							675	615	570
m							17,41	18,79	20,27

- CE**
- NO CE**
- MANUAL**
- RADIO**

*) Theoretical lifting capacity

HC 231 X



EES Extra Extension Speed
SDS Smooth Descent System
P-LCS Proportional Lift Control System
LAS Liftrod Articulating System

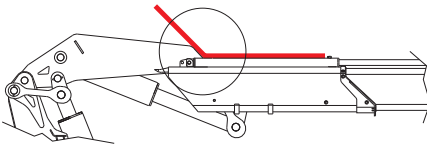

Second boom with negative angle in order to simplify operations in difficult access conditions

MODELS	LIFTING MOMENT	MAX VERTICAL REACH (HYDR)	SLEWING ANGLE	SLEWING TIME	MAX WORKING HEEL	WORKING PRESSURE	CRANE WEIGHT WITHOUT STABILIZERS	OIL TANK CAPACITY	OIL FLOW	DIMENSIONS mm B x h x S
	tm	m	°	s/180°	°	bar	kg	l	l/min	
HC231 E2	21,7	12,0	415	20	4	345	2210	130	70	2520x2300x930
HC231 E3	-	14,1	415	20	4	345	2360	130	70	2520x2300x930
HC231 E4	-	16,2	415	20	4	345	2510	130	70	2520x2300x930
HC231 E5	-	18,4	415	20	4	345	2630	130	70	2520x2300x930
HC231 E6	-	20,7	415	20	4	345	2725	130	70	2520x2300x930
HC231 E3J3	-	22,2	415	20	3	-	3020	130	70	2520x2695x1050
HC231 E4J3	-	23,8	415	20	3	-	3000	130	70	2520x2600x1050
HC231 E5J2	-	23,9	415	20	3	-	2905	130	70	2520x2550x1050

HC 235e



EES
SDS
P-LCS
LAS

HC235e E2

kg	21705*	4990	3380	2560
m	1,00	4,35	6,32	8,29

HC235e E3

kg	21160*	4865	3245	2420	1915	1460	1130	725
m	1,00	4,35	6,32	8,29	10,36	12,51	14,73	17,01

HC235e E4

kg	20710*	4675	3085	2270	1770	1460	1130	890	600
m	1,00	4,43	6,40	8,37	10,44	12,51	14,72	17,01	19,11

HC235e E5

kg	20270*	4495	2940	2140	1640	1340	1130	890	755
m	1,00	4,51	6,48	8,45	10,52	12,59	14,72	17,01	19,11

HC235e E6

kg	19985*	4345	2830	2040	1550	1280	1060	895	755
m	1,00	4,60	6,57	8,54	10,61	12,68	14,81	17,01	19,11

HC235e E3J3

kg					905	775	675	605
m					13,36	15,06	16,81	18,56

HC235e E4J3

kg						715	635	570	520
m						15,43	16,99	18,55	20,11

HC235e E5J2

kg								675	615	570
m								17,41	18,79	20,27

CE	<input checked="" type="checkbox"/>
NO CE	<input checked="" type="checkbox"/>
MANUAL	<input type="checkbox"/>
RADIO	<input checked="" type="checkbox"/>

*) Theoretical lifting capacity

HC 235e



EES Extra Extension Speed
SDS Smooth Descent System
P-LCS Proportional Lift Control System
LAS Liftrod Articulating System

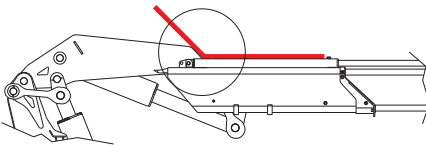

Second boom with negative angle in order to simplify operations in difficult access conditions

MODELS	LIFTING MOMENT	MAX VERTICAL REACH (HYDR)	SLEWING ANGLE	SLEWING TIME	MAX WORKING HEEL	WORKING PRESSURE	CRANE WEIGHT WITHOUT STABILIZERS	OIL TANK CAPACITY	OIL FLOW	DIMENSIONS mm B x h x S
	tm	m	°	s/180°	°	bar	kg	l	l/min	
HC235e E2	21,7	12,0	Endless	30	4	345	2370	130	70	2535x2335x960
HC235e E3	-	14,1	Endless	30	4	345	2520	130	70	2535x2335x960
HC235e E4	-	16,2	Endless	30	4	345	2670	130	70	2535x2335x960
HC235e E5	-	18,4	Endless	30	4	345	2790	130	70	2535x2335x960
HC235e E6	-	20,7	Endless	30	4	345	2885	130	70	2535x2335x960
HC235e E3J3	-	22,2	Endless	30	3	-	3180	130	70	2550x2685x1095
HC235e E4J3	-	23,8	Endless	30	3	-	3160	130	70	2550x2590x1095
HC235e E5J2	-	23,9	Endless	30	3	-	3065	130	70	2540x2530x1095

HC 243

EES

SDS

LAS



HC243

E2

kg	22534*	5265	3595	2730
m	1,00	4,28	6,18	8,08

- CE**
- NO CE**
- MANUAL**
- RADIO**

HC243

E3

kg	22149*	5175	3495	2625	2080	1600	1300	1000
m	1,00	4,28	6,18	8,08	10,11	12,22	14,44	16,65

HC243

E4

kg	21289*	4885	3270	2425	1895	1565	1240	1000	605
m	1,00	4,36	6,26	8,33	10,19	12,22	14,44	16,65	18,90

HC243

E5

kg	20468*	4610	3055	2235	1720	1400	1180	900	750	535
m	1,00	4,44	6,34	8,24	10,27	12,30	14,43	16,65	18,90	21,18

HC243

E6

kg	20067*	4430	2910	2105	1595	1275	1055	905	605	535
m	1,00	4,53	6,43	8,33	10,36	12,39	14,52	16,65	18,90	21,18

HC243

E7

kg	19684*	4270	2780	1985	1480	1160	940	795	695	570	350
m	1,00	4,61	6,51	8,41	10,44	12,47	14,60	16,73	18,90	21,18	23,28

HC243

E8

kg	19411*	4130	2670	1890	1390	1070	850	705	605	535	450
m	1,00	4,70	6,60	8,50	10,53	12,56	14,69	16,82	18,98	21,18	23,28

HC243

E4J3

kg							660	570	500	450	375	315
m							15,21	16,91	18,66	20,41	22,30	24,21

HC243

E5J3

kg								530	475	430	400	345	300
m								17,26	18,82	20,38	21,94	23,60	25,38

HC243

E6J2

kg									540	500	460
m									19,38	20,76	22,24

*) Theoretical lifting capacity

HC 243



EES Extra Extension Speed
SDS Smooth Descent System
LAS Liftrod Articulating System

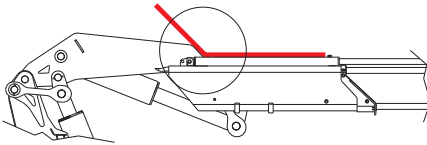

Second boom with negative angle in order to simplify operations in difficult access conditions

MODELS	LIFTING MOMENT	MAX VERTICAL REACH (HYDR)	SLEWING ANGLE	SLEWING TIME	MAX WORKING HEEL	WORKING PRESSURE	CRANE WEIGHT WITHOUT STABILIZERS	OIL TANK CAPACITY	OIL FLOW	DIMENSIONS mm B x h x S
	tm	m	°	s/180°	°	bar	kg	l	l/min	
HC243 E2	22,5	11,7	415	20	4	315	2315	130	80	2520x2300x935
HC243 E3	-	13,8	415	20	4	310	2455	130	80	2520x2300x935
HC243 E4	-	15,9	415	20	4	310	2595	130	80	2520x2300x935
HC243 E5	-	18,1	415	20	4	310	2720	130	80	2520x2300x935
HC243 E6	-	20,3	415	20	4	310	2825	130	80	2520x2300x935
HC243 E7	-	22,5	415	20	4	310	2945	130	80	2520x2300x1005
HC243 E8	-	24,8	415	20	4	310	3035	130	80	2520x2300x1005
HC243 E4J3	-	24,1	415	20	4	325	3255	130	80	2520x2715x1055
HC243 E5J3	-	25,6	415	20	4	330	3210	130	80	2520x2615x1055
HC243 E6J2	-	25,9	415	20	4	325	3100	130	80	2520x2605x1055

HC 243K

EES
SDS
LAS

HC243K E2

kg	22715*	6090	4455	3190
m	1,00	3,72	5,06	7,03

HC243K E3

kg	21875*	5865	4255	3010	2305
m	1,00	3,73	5,06	7,03	9,10

HC243K E4

kg	21145*	5550	4005	2800	2115	1710
m	1,00	3,81	5,14	7,11	9,18	11,25

*) Theoretical lifting capacity

CE	<input checked="" type="checkbox"/>
NO CE	<input checked="" type="checkbox"/>
MANUAL	<input checked="" type="checkbox"/>
RADIO	<input checked="" type="checkbox"/>

HC 243K



EES Extra Extension Speed
SDS Smooth Descent System
LAS Liftrod Articulating System

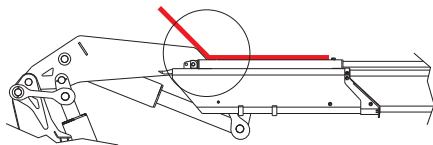

Second boom with negative angle in order to simplify operations in difficult access conditions

MODELS	LIFTING MOMENT	MAX VERTICAL REACH (HYDR)	SLEWING ANGLE	SLEWING TIME	MAX WORKING HEEL	WORKING PRESSURE	CRANE WEIGHT WITHOUT STABILIZERS	OIL TANK CAPACITY	OIL FLOW	DIMENSIONS
	tm	m	°	s/180°	°	bar	kg	l	l/min	mm B x h x S
HC243K E2	22,7	10,7	415	20	4	300	2245	130	80	2520x2300x930
HC243K E3	-	12,8	415	20	4	300	2385	130	80	2520x2300x930
HC243K E4	-	14,9	415	20	4	300	2525	130	80	2520x2300x930

HC 245



HC245 E2

kg	23510*	5435	3770	2910
m	1,00	4,28	6,18	8,08

HC245 E3

kg	22855*	5340	3665	2795	2255	1765	1455	1000
m	1,00	4,28	6,18	8,08	10,11	12,22	14,44	16,65

HC245 E4

kg	21995*	5045	3430	2585	2055	1725	1390	1140	605
m	1,00	4,36	6,26	8,33	10,19	12,22	14,44	16,65	18,90

HC245 E5

kg	21155*	4765	3210	2385	1870	1545	1320	1025	870	535
m	1,00	4,44	6,34	8,24	10,27	12,30	14,43	16,65	18,90	21,18

HC245 E6

kg	20770*	4585	3060	2250	1730	1405	1180	1035	700	630
m	1,00	4,53	6,43	8,33	10,36	12,39	14,52	16,65	18,90	21,18

HC245 E7

kg	20350*	4415	2920	2120	1610	1280	1050	905	805	670	420
m	1,00	4,61	6,51	8,41	10,44	12,47	14,60	16,73	18,90	21,18	23,28

HC245 E8

kg	20115*	4280	2810	2020	1510	1185	960	805	700	630	540
m	1,00	4,70	6,60	8,50	10,53	12,56	14,69	16,82	18,98	21,18	23,28

HC245 E4J3

kg						730	640	565	515	435	370
m						15,21	16,91	18,66	20,41	22,30	24,21

HC245 E5J3

kg							600	540	495	465	405	355
m							17,26	18,82	20,38	21,94	23,60	25,38

HC245 E6J2

kg									570	530	490
m									19,38	20,76	22,24

CE	<input checked="" type="checkbox"/>
NO CE	<input checked="" type="checkbox"/>
MANUAL	<input checked="" type="checkbox"/>
RADIO	<input checked="" type="checkbox"/>

*) Theoretical lifting capacity

HC 245



- EES** Extra Extension Speed
- SDS** Smooth Descent System
- LCS** Lift Control System
- LAS** Liftrod Articulating System

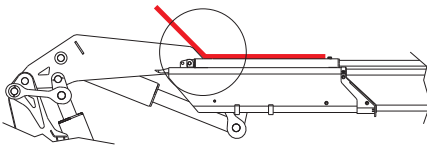

Second boom with negative angle in order to simplify operations in difficult access conditions

MODELS	LIFTING MOMENT	MAX VERTICAL REACH (HYDR)	SLEWING ANGLE	SLEWING TIME	MAX WORKING HEEL	WORKING PRESSURE	CRANE WEIGHT WITHOUT STABILIZERS	OIL TANK CAPACITY	OIL FLOW	DIMENSIONS
	tm	m	°	s/180°	°	bar	kg	l	l/min	mm B x h x S
HC245 E2	23,3	11,7	415	20	4	330	2315	130	80	2520x2300x935
HC245 E3	-	13,8	415	20	4	330	2455	130	80	2520x2300x935
HC245 E4	-	15,9	415	20	4	330	2595	130	80	2520x2300x935
HC245 E5	-	18,1	415	20	4	330	2720	130	80	2520x2300x935
HC245 E6	-	20,3	415	20	4	330	2825	130	80	2520x2300x935
HC245 E7	-	22,5	415	20	4	330	2945	130	80	2520x2300x1005
HC245 E8	-	24,8	415	20	4	330	3035	130	80	2520x2300x1005
HC245 E4J3	-	24,1	415	20	3	335	3255	130	80	2520x2715x1055
HC245 E5J3	-	25,6	415	20	3	335	3210	130	80	2520x2615x1055
HC245 E6J2	-	25,9	415	20	3	330	3100	130	80	2520x2605x1055

HC 261

EES
SDS
P-LCS
LAS



HC261 E2

kg	24800*	5795	3965	3015
m	1,00	4,28	6,18	8,08

HC261 E3

kg	24310*	5680	3850	2895	2300	1845	1500	1000
m	1,00	4,28	6,18	8,08	10,11	12,22	14,44	16,65

HC261 E4

kg	23780*	5455	3670	2735	2145	1775	1430	1175	605
m	1,00	4,36	6,26	8,33	10,19	12,22	14,44	16,65	18,90

HC261 E5

kg	23350*	5260	3515	2595	2010	1640	1385	1145	960	535
m	1,00	4,44	6,34	8,24	10,27	12,30	14,43	16,65	18,90	21,18

HC261 E6

kg	22965*	5070	3365	2460	1880	1510	1260	1085	765	680
m	1,00	4,53	6,43	8,33	10,36	12,39	14,52	16,65	18,90	21,18

HC261 E7

kg	22345*	4910	3240	2345	1770	1405	1150	980	855	725	630
m	1,00	4,61	6,51	8,41	10,44	12,47	14,60	16,73	18,90	21,18	23,28

HC261 E8

kg	22345*	4755	3120	2240	1670	1310	1060	885	765	680	580
m	1,00	4,70	6,60	8,50	10,53	12,56	14,69	16,82	18,98	21,18	23,28

HC261 E4J3

kg							855	745	660	595	510	435
m							15,21	16,91	18,66	20,41	22,30	24,21

HC261 E5J3

kg								695	625	570	525	465	415
m								17,26	18,82	20,38	21,94	23,60	25,38

HC261 E6J2

kg									650	600	560
m									19,38	20,76	22,24

CE	<input checked="" type="checkbox"/>
NO CE	<input checked="" type="checkbox"/>
MANUAL	<input checked="" type="checkbox"/>
RADIO	<input checked="" type="checkbox"/>

*) Theoretical lifting capacity

HC 261 X



- EES** Extra Extension Speed
- SDS** Smooth Descent System
- P-LCS** Proportional Lift Control System
- LAS** Liftrod Articulating System

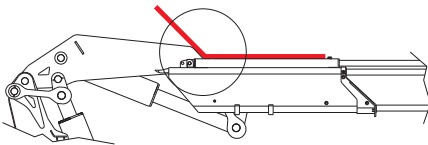

Second boom with negative angle in order to simplify operations in difficult access conditions

MODELS	LIFTING MOMENT	MAX VERTICAL REACH (HYDR)	SLEWING ANGLE	SLEWING TIME	MAX WORKING HEEL	WORKING PRESSURE	CRANE WEIGHT WITHOUT STABILIZERS	OIL TANK CAPACITY	OIL FLOW	DIMENSIONS
	tm	m	°	s/180°	°	bar	kg	l	l/min	mm B x h x S
HC261 E2	24,8	11,7	415	20	4	345	2315	130	80	2520x2300x935
HC261 E3	-	13,8	415	20	4	345	2455	130	80	2520x2300x935
HC261 E4	-	15,9	415	20	4	345	2595	130	80	2520x2300x935
HC261 E5	-	18,1	415	20	4	345	2720	130	80	2520x2300x935
HC261 E6	-	20,3	415	20	4	345	2825	130	80	2520x2300x935
HC261 E7	-	22,5	415	20	4	345	2945	130	80	2520x2300x1005
HC261 E8	-	24,8	415	20	4	345	3035	130	80	2520x2300x1005
HC261 E4J3	-	24,1	415	20	3	355	3255	130	80	2520x2715x1055
HC261 E5J3	-	25,6	415	20	3	350	3210	130	80	2520x2615x1055
HC261 E6J2	-	25,9	415	20	3	350	3100	130	80	2520x2605x1055

HC 265e

- EES**
- SDS**
- P-LCS**
- LAS**



HC265e

E2

kg	24800*	5795	3965	3015
m	1,00	4,28	6,18	8,08

HC265e

E3

kg	24310*	5680	3850	2895	2300	1845	1500	1000
m	1,00	4,28	6,18	8,08	10,11	12,22	14,44	16,65

HC265e

E4

kg	23780*	5455	3670	2735	2145	1775	1430	1175	605
m	1,00	4,36	6,26	8,33	10,19	12,22	14,44	16,65	18,90

HC265e

E5

kg	23350*	5260	3515	2595	2010	1640	1385	1145	960	535
m	1,00	4,44	6,34	8,24	10,27	12,30	14,43	16,65	18,90	21,18

HC265e

E6

kg	22965*	5070	3365	2460	1880	1510	1260	1085	765	680
m	1,00	4,53	6,43	8,33	10,36	12,39	14,52	16,65	18,90	21,18

HC265e

E7

kg	22635*	4910	3240	2345	1770	1405	1150	980	855	725	630
m	1,00	4,61	6,51	8,41	10,44	12,47	14,60	16,73	18,90	21,18	23,28

HC265e

E8

kg	22345*	4755	3120	2240	1670	1310	1060	885	765	680	580
m	1,00	4,70	6,60	8,50	10,53	12,56	14,69	16,82	18,98	21,18	23,28

HC265e

E4J3

kg						855	745	660	595	510	435
m						15,21	16,91	18,66	20,41	22,30	24,21

HC265e

E5J3

kg								695	625	570	525	465	415
m								17,26	18,82	20,38	21,94	23,60	25,38

HC265e

E6J2

kg										650	600	560
m										19,38	20,76	22,24

- CE**
- NO CE**
- MANUAL**
- RADIO**

*) Theoretical lifting capacity

HC 265e X



- EES** Extra Extension Speed
- SDS** Smooth Descent System
- P-LCS** Proportional Lift Control System
- LAS** Liftrod Articulating System

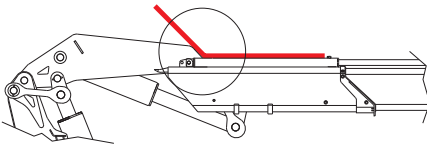

Second boom with negative angle in order to simplify operations in difficult access conditions

MODELS	LIFTING MOMENT	MAX VERTICAL REACH (HYDR)	SLEWING ANGLE	SLEWING TIME	MAX WORKING HEEL	WORKING PRESSURE	CRANE WEIGHT WITHOUT STABILIZERS	OIL TANK CAPACITY	OIL FLOW	DIMENSIONS
	tm	m	°	s/180°	°	bar	kg	l	l/min	mm B x h x S
HC265e E2	24,8	11,7	Endless	30	4	345	2460	130	80	2530x2335x980
HC265e E3	-	13,8	Endless	30	4	345	2600	130	80	2530x2335x980
HC265e E4	-	15,9	Endless	30	4	345	2740	130	80	2530x2335x980
HC265e E5	-	18,1	Endless	30	4	345	2865	130	80	2530x2335x980
HC265e E6	-	20,3	Endless	30	4	345	2970	130	80	2530x2335x980
HC265e E7	-	22,5	Endless	30	4	345	3090	130	80	2530x2335x1055
HC265e E8	-	24,8	Endless	30	4	345	3180	130	80	2530x2335x1055
HC265e E4J3	-	24,1	Endless	30	3	355	3400	130	80	2550x2700x1100
HC265e E5J3	-	25,6	Endless	30	3	350	3355	130	80	2550x2595x1100
HC265e E6J2	-	25,9	Endless	30	3	350	3245	130	80	2540x2580x1100

HC 291

EES

SDS

LCS

LAS



HC291 E2

kg	27310*	11390**	6000	4165	3190	2415	1890	1470	
m	1,00	2,40	4,51	6,38	8,25	10,23	12,20	14,38	

HC291 E3

kg	27090*	11270**	5940	4035	3040	2415	1890	1470	1155
m	1,00	2,40	4,56	6,43	8,30	10,25	12,20	14,38	16,57

HC291 E4

kg	26150*	10880**	5735	3885	2900	2285	1890	1470	1155	895
m	1,00	2,40	4,56	6,43	8,30	10,25	12,20	14,38	16,57	18,86

HC291 E5

kg	25610*	10670**	5515	3710	2740	2125	1750	1470	1155	895	705
m	1,00	2,40	4,64	6,51	8,38	10,33	12,28	14,38	16,57	18,86	21,14

HC291 E6

kg	25260*	10510**	5340	3570	2610	2010	1620	1345	1155	895	705	565
m	1,00	2,40	4,73	6,60	8,47	10,42	12,37	14,47	16,57	18,86	21,14	23,33

HC291 E7

kg	24800*	10310**	5145	3410	2465	1880	1500	1225	1035	895	705	565
m	1,00	2,40	4,82	6,69	8,56	10,51	12,46	14,56	16,66	18,86	21,14	23,33

HC291 E8

kg	24340*	10140**	4965	3275	2345	1770	1390	1125	935	805	705	565
m	1,00	2,40	4,90	6,77	8,64	10,59	12,54	14,64	16,74	18,94	21,14	23,33

HC291 E6J4

kg													475	420	375	345	315	245
m													19,65	21,25	22,80	24,19	25,79	27,60

CE	<input checked="" type="checkbox"/>
NO CE	<input checked="" type="checkbox"/>
MANUAL	<input checked="" type="checkbox"/>
RADIO	<input checked="" type="checkbox"/>

*) Theoretical lifting capacity
 **) Fixed hook capacity

HC 291



- EES** Extra Extension Speed
- SDS** Smooth Descent System
- LCS** Lift Control System
- LAS** Liftrod Articulating System

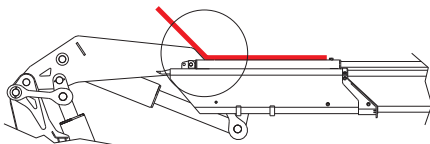

Second boom with negative angle in order to simplify operations in difficult access conditions

MODELS	LIFTING MOMENT	MAX VERTICAL REACH (HYDR)	SLEWING ANGLE	SLEWING TIME	MAX WORKING HEEL	WORKING PRESSURE	CRANE WEIGHT WITHOUT STABILIZERS	OIL TANK CAPACITY	OIL FLOW	DIMENSIONS
	tm	m	°	s/180°	°	bar	kg	l	l/min	
HC291 E2	27,3	11,9	425	22	4	325	2635	180	80	2510x2350x1010
HC291 E3	-	13,8	425	22	4	325	2795	180	80	2510x2350x1010
HC291 E4	-	15,8	425	22	4	325	2950	180	80	2510x2350x1010
HC291 E5	-	17,9	425	22	4	325	3090	180	80	2510x2350x1040
HC291 E6	-	20,1	425	22	4	325	3215	180	80	2510x2350x1060
HC291 E7	-	22,4	425	22	4	325	3330	180	80	2510x2350x1160
HC291 E8	-	24,7	425	22	4	325	3430	180	80	2510x2350x1180
HC291 E6J4	-	29,1	425	22	4	325	3790	180	80	2510x2705x1190

HC 331

EES
SDS
LAS



HC331 E1

kg	31220*	11930**	7770	5430	3900	2815	2115			
m	1,00	2,52	3,98	5,75	7,55	9,60	11,69			

HC331 E2

kg	30290*	11625**	7610	5170	3900	2815	2115	1600		
m	1,00	2,52	3,98	5,75	7,60	9,60	11,69	13,98		

HC331 E3

kg	29600*	11320**	7400	5015	3715	2895	2115	1600	1220	
m	1,00	2,52	4,00	5,75	7,60	9,60	11,70	14,00	16,30	

HC331 E4

kg	29010*	11010**	7075	4765	3495	2680	2195	1600	1220	960
m	1,00	2,52	4,10	5,85	7,70	9,70	11,70	14,00	16,30	18,65

HC331 E5

kg	28500*	10705**	6785	4555	3320	2510	2020	1680	1220	960	785
m	1,00	2,52	4,20	5,95	7,80	9,80	11,80	14,00	16,30	18,65	20,75

HC331 E6

kg	27800*	10450**	6540	4335	3125	2345	1860	1520	1295	960	785
m	1,00	2,52	4,25	6,10	7,90	9,90	11,90	14,10	16,30	18,65	20,75

HC331 E7

kg	27210*	10195**	6185	4125	2970	2200	1715	1375	1150	1005	785
m	1,00	2,52	4,40	6,20	8,10	10,10	12,10	14,30	16,50	18,65	20,75

HC331 E8

kg	26780*	10145**	5950	3920	2785	2035	1585	1255	1035	885	785	400
m	1,00	2,52	4,50	6,30	8,20	10,20	12,20	14,40	16,60	18,80	20,95	23,40

HC331 E4J4

kg									1090	940	815	695	605	420
m									14,60	16,30	18,10	19,80	21,60	23,40

HC331 E5J4

kg										705	605	525	460	420	330
m										16,80	18,50	20,20	22,00	23,80	25,70

CE	<input checked="" type="checkbox"/>
NO CE	<input checked="" type="checkbox"/>
MANUAL	<input checked="" type="checkbox"/>
RADIO	<input checked="" type="checkbox"/>

*) Theoretical lifting capacity
**) Fixed hook capacity

HC 331



EES Extra Extension Speed
SDS Smooth Descent System
LAS Liftrod Articulating System

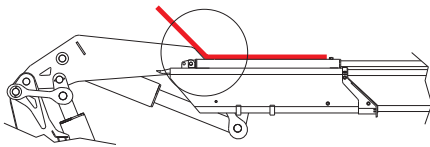

Second boom with negative angle in order to simplify operations in difficult access conditions

MODELS	LIFTING MOMENT	MAX VERTICAL REACH (HYDR)	SLEWING ANGLE	SLEWING TIME	MAX WORKING HEEL	WORKING PRESSURE	CRANE WEIGHT WITHOUT STABILIZERS	OIL TANK CAPACITY	OIL FLOW	DIMENSIONS mm B x h x S
	tm	m	°	s/180°	°	bar	kg	l	l/min	
HC331 E1	31,2	9,9	397	25	4	305	3050	160	45	2540x2355x1170
HC331 E2	-	11,8	397	25	4	305	3280	160	45	2540x2355x1170
HC331 E3	-	13,8	397	25	4	305	3500	160	45	2540x2355x1170
HC331 E4	-	15,8	397	25	4	305	3730	160	45	2540x2355x1170
HC331 E5	-	18,1	397	25	4	305	3900	160	45	2540x2355x1170
HC331 E6	-	20,4	397	25	4	305	4060	160	45	2540x2405x1170
HC331 E7	-	22,7	397	25	4	305	4180	160	45	2540x2490x1300
HC331 E8	-	25,0	397	25	4	305	4300	160	45	2540x2550x1300
HC331 E4J4	-	25,7	397	30	4	290	4570	160	45	2540x2620x1330
HC331 E5J4	-	28,0	397	30	4	295	4740	160	45	2545x2620x1330

HC 361

- EES**
- SDS**
- LCS**
- LAS**



HC361 E1

kg	32400*	12340**	7980	5635	4085	3070	2355		
m	1,00	2,52	3,98	5,75	7,55	9,60	11,69		

HC361 E2

kg	31120*	11930**	7820	5370	4080	3070	2355	1825
m	1,00	2,52	3,98	5,75	7,60	9,60	11,69	13,98

HC361 E3

kg	30400*	11625**	7600	5200	3900	3070	2355	1825	1425
m	1,00	2,52	4,00	5,75	7,60	9,60	11,70	14,00	16,30

HC361 E4

kg	29830*	11320**	7275	4950	3670	2845	2355	1805	1425	1120
m	1,00	2,52	4,10	5,85	7,70	9,70	11,70	14,00	16,30	18,65

HC361 E5

kg	29300*	11010**	6975	4730	3485	2660	2175	1825	1425	1120	885
m	1,00	2,52	4,20	5,95	7,80	9,80	11,80	14,00	16,30	18,65	20,75

HC361 E6

kg	28600*	10755**	6730	4510	3280	2485	2000	1650	1425	1120	885
m	1,00	2,52	4,25	6,10	7,90	9,90	11,90	14,10	16,30	18,65	20,75

HC361 E7

kg	28050*	10500**	6375	4290	3125	2345	1850	1500	1275	1120	885
m	1,00	2,52	4,40	6,20	8,10	10,10	12,10	14,30	16,50	18,65	20,75

HC361 E8

kg	27590*	10450**	6130	4085	2925	2170	1705	1365	1140	990	885	410
m	1,00	2,52	4,50	6,30	8,20	10,20	12,20	14,40	16,60	18,80	20,95	23,40

HC361 E4J4

kg								1175	1020	895	805	705	490
m								14,60	16,30	18,10	19,80	21,60	23,40

HC361 E5J4

kg								765	665	585	510	470	360
m								16,80	18,50	20,20	22,00	23,80	25,70

- CE**
- NO CE**
- MANUAL**
- RADIO**

*) Theoretical lifting capacity
 **) Fixed hook capacity

HC 361



- EES** Extra Extension Speed
- SDS** Smooth Descent System
- LCS** Lift Control System
- LAS** Liftrød Articulating System

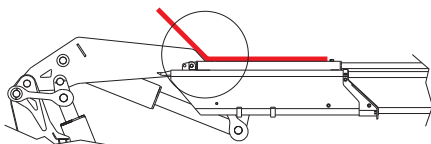

Second boom with negative angle in order to simplify operations in difficult access conditions

MODELS	LIFTING MOMENT	MAX VERTICAL REACH (HYDR)	SLEWING ANGLE	SLEWING TIME	MAX WORKING HEEL	WORKING PRESSURE	CRANE WEIGHT WITHOUT STABILIZERS	OIL TANK CAPACITY	OIL FLOW	DIMENSIONS
	tm	m	°	s/180°	°	bar	kg	l	l/min	
HC361 E1	32,4	9,9	397	25	4	315	3050	160	45	2540x2355x1170
HC361 E2	-	11,8	397	25	4	315	3280	160	45	2540x2355x1170
HC361 E3	-	13,8	397	25	4	315	3500	160	45	2540x2355x1170
HC361 E4	-	15,8	397	25	4	315	3730	160	45	2540x2355x1170
HC361 E5	-	18,1	397	25	4	315	3900	160	45	2540x2355x1170
HC361 E6	-	20,4	397	25	4	315	4060	160	45	2540x2405x1170
HC361 E7	-	22,7	397	25	4	315	4180	160	45	2540x2490x1300
HC361 E8	-	25,0	397	25	4	315	4300	160	45	2540x2550x1300
HC361 E4J4	-	25,7	397	30	4	300	4570	160	45	2540x2620x1330
HC361 E5J4	-	28,0	397	30	4	310	4740	160	45	2545x2620x1330

HC 501

- EES**
- SDS**
- TCU**
- LCS**
- LAS**



HC501 E2

kg	44990*	22685*	10735	7580	5805
m	1,00	1,95	4,12	5,90	7,75

HC501 E3

kg	43440*	22225*	10240	7240	5515	4425	3460	2735	2195
m	1,00	1,95	4,23	6,00	7,85	9,80	11,80	13,90	16,00

HC501 E4

kg	42770*	21935*	9830	6940	5225	4160	3460	2735	2195	1745
m	1,00	1,95	4,35	6,10	7,95	9,90	11,80	13,90	16,00	18,20

HC501 E5

kg	41910*	21490*	9630	6710	5000	3905	3210	2735	2195	1745	1380
m	1,00	1,95	4,35	6,10	7,95	9,90	11,80	13,90	16,00	18,20	20,40

HC501 E6

kg	41040*	21045*	9325	6450	4765	3700	3015	2525	2195	1745	1380	1055
m	1,00	1,95	4,40	6,15	8,00	9,90	11,90	13,90	16,00	18,20	20,40	22,60

HC501 E7

kg	40200*	20615*	9125	6245	4565	3485	2805	2320	1990	1745	1380	1055
m	1,00	1,95	4,40	6,15	8,00	9,90	11,90	13,90	16,00	18,20	20,40	22,60

HC501 E8

kg	39500*	20255*	8770	5985	4350	3300	2610	2115	1800	1555	1380	1055
m	1,00	1,95	4,50	6,20	8,10	10,00	12,00	14,00	16,10	18,20	20,40	22,60

HC501 E6J4

kg												980	855	765	705	655	480
m												18,80	20,50	22,20	24,00	25,80	27,70

CE	<input checked="" type="checkbox"/>
NO CE	<input checked="" type="checkbox"/>
MANUAL	<input checked="" type="checkbox"/>
RADIO	<input checked="" type="checkbox"/>

*) Theoretical lifting capacity

HC 501



- EES** Extra Extension Speed
- SDS** Smooth Descent System
- TCU** Total Control Unit
- LCS** Lift Control System
- LAS** Liftrod Articulating System

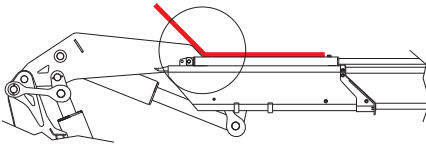

Second boom with negative angle in order to simplify operations in difficult access conditions

MODELS	LIFTING MOMENT	MAX VERTICAL REACH (HYDR)	SLEWING ANGLE	SLEWING TIME	MAX WORKING HEEL	WORKING PRESSURE	CRANE WEIGHT WITHOUT STABILIZERS	OIL TANK CAPACITY	OIL FLOW	DIMENSIONS
	tm	m	°	s/180°	°	bar	kg	l	l/min	mm B x h x S
HC501 E2	45,0	12,1	400	25	4	320	4040	210	80	2505x2460x1275
HC501 E3	-	14,1	400	25	4	320	4290	210	80	2505x2460x1275
HC501 E4	-	16,1	400	25	4	320	4570	210	80	2505x2460x1275
HC501 E5	-	18,2	400	25	4	320	4810	210	80	2505x2460x1285
HC501 E6	-	20,3	400	25	4	320	5010	210	80	2505x2460x1285
HC501 E7	-	22,5	400	25	4	320	5200	210	80	2505x2460x1400
HC501 E8	-	24,7	400	25	4	320	5380	210	80	2510x2480x1400
HC501 E6J4	-	30,1	400	25	4	320	5880	210	80	2515x2725x1470

HC 601e

EES
SDS
LAS



HC601e E2

kg	57480	13000	9240	7185
m	1,00*	4,35	6,15	8,00

HC601e E4

kg	54680	12260	8625	6610	5270	4400	3195	2760	2045	1820
m	1,00*	4,46	6,26	8,06	10,00	11,96	14,08	16,18	18,52	20,70

HC601e E6

kg	51920	11590	8000	6005	4685	3820	3195	2760	2045	1820	1500	1150
m	1,00*	4,48	6,28	8,10	10,05	11,98	14,08	16,18	18,52	20,70	22,85	25,00

HC601e E8

kg	50720	10860	7450	5530	4240	3395	2780	2350	2045	1820	1500	1150
m	1,00*	4,67	6,47	8,30	10,25	12,20	14,30	16,40	18,52	20,70	22,85	25,00

HC601e E6 J2002

kg								1300	1180	1080	820	760
m								19,50	21,10	22,70	24,40	26,10

HC601e E6 J2004

kg									1120	1010	900	820	760	570	530
m									19,60	21,20	22,80	24,40	26,10	28,00	29,80

HC601e E6 J2006

kg										960	850	755	675	620	570	530	420
m										19,65	21,30	22,90	24,50	26,20	28,00	29,80	31,00

HC601e E6 J1206

kg										1200	1060	950	865	795	735	685	500
m										19,65	21,30	22,90	24,50	26,20	28,00	29,80	31,00

*) Theoretical lifting capacity

CE	<input checked="" type="checkbox"/>
NO CE	<input checked="" type="checkbox"/>
MANUAL	<input type="checkbox"/>
RADIO	<input checked="" type="checkbox"/>

HC 601e



EES Extra Extension Speed
SDS Smooth Descent System
LAS Liftrod Articulating System

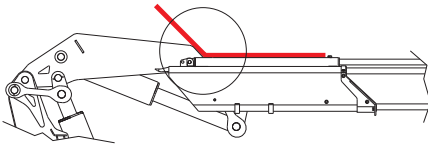

Second boom with negative angle in order to simplify operations in difficult access conditions

MODELS	LIFTING MOMENT	MAX VERTICAL REACH (HYDR)	SLEWING ANGLE	SLEWING TIME (WITH 2 GEAR MOTOR)	MAX WORKING HEEL	WORKING PRESSURE	CRANE WEIGHT WITHOUT STABILIZERS	OIL TANK CAPACITY	OIL FLOW	DIMENSIONS mm B x h x S
	tm	m	°	s/180°	°	bar	kg	l	l/min	
HC601e E2	57,5	11,9	Endless	40	4	335	4625	250	100	2530x2430x1480
HC601e E4	-	15,9	Endless	40	4	335	5190	250	100	2530x2430x1480
HC601e E6	-	20,3	Endless	50	4	335	5715	250	100	2530x2430x1480
HC601e E8	-	24,7	Endless	50	4	335	6125	300	100	2550x2740x1635
HC601e E6 J2002	-	26,6	Endless	60	3	-	6820	250/300	100	2550x2740x1665
HC601e E6 J2004	-	30,1	Endless	60	3	-	7035	250/300	100	2550x2740x1665
HC601e E6 J2006	-	33,8	Endless	60	3	-	7205	250/300	100	2550x2740x1665
HC601e E6 J1206	-	33,8	Endless	60	3	-	6905	250/300	100	2550x2780x1665

HC 661e X

EES
SDS
P-LCS
LAS



HC661e E2

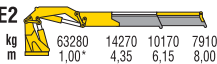

HC661e E4

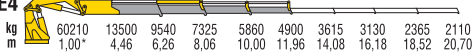

HC661e E6

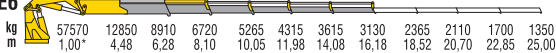

HC661e E8

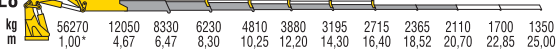

HC661e E6 J2002

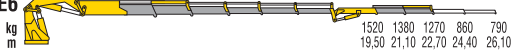

HC661e E6 J2004



HC661e E6 J2006



HC661e E6 J1206

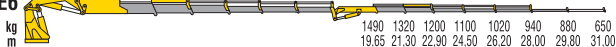

*) Theoretical lifting capacity

CE	<input checked="" type="checkbox"/>
NO CE	<input checked="" type="checkbox"/>
MANUAL	<input checked="" type="checkbox"/>
RADIO	<input checked="" type="checkbox"/>

HC 661e



EES Extra Extension Speed
SDS Smooth Descent System
P-LCS Proportional Lift Control System
LAS Liftrod Articulating System

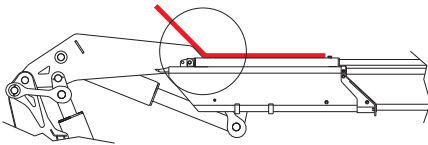

Second boom with negative angle in order to simplify operations in difficult access conditions

MODELS	LIFTING MOMENT	MAX VERTICAL REACH (HYDR)	SLEWING ANGLE	SLEWING TIME (WITH 2 GEAR MOTOR)	MAX WORKING HEEL	WORKING PRESSURE	CRANE WEIGHT WITHOUT STABILIZERS	OIL TANK CAPACITY	OIL FLOW	DIMENSIONS mm B x h x S
	tm	m	°	s/180°	°	bar	kg	l	l/min	
HC661e E2	63,2	11,9	Endless	40	4	365	4625	250	100	2530x2430x1480
HC661e E4	-	15,9	Endless	40	4	365	5190	250	100	2530x2430x1480
HC661e E6	-	20,3	Endless	50	4	365	5715	250	100	2530x2430x1480
HC661e E8	-	24,7	Endless	50	4	365	6125	300	100	2550x2740x1635
HC661e E6 J2002	-	26,6	Endless	60	3	-	6820	250/300	100	2550x2740x1665
HC661e E6 J2004	-	30,1	Endless	60	3	-	7035	250/300	100	2550x2740x1665
HC661e E6 J2006	-	33,8	Endless	60	3	-	7205	250/300	100	2550x2740x1665
HC661e E6 J1206	-	33,8	Endless	60	3	-	6905	250/300	100	2550x2780x1665

HC 801

- EES**
- SDS**
- TCU**
- LCS**
- LAS**



HC801 E2

kg	73980*	24660*	17940	12830	9800
m	1,00	3,00	4,05	5,75	7,55

HC801 E4

kg	70290*	23430*	17035	12015	9050	7155	5920
m	1,00	3,00	4,12	5,85	7,65	9,55	11,45

HC801 E6

kg	67710*	22570*	15855	11160	8355	6480	5285	4440	3845	2920	2605	1950
m	1,00	3,00	4,27	6,00	7,77	9,70	11,60	13,60	15,60	17,60	19,60	22,00

HC801 E8

kg	65940*	21980*	15440	10695	7845	6020	4850	3975	3360	2920	2605	1950	1760	1360
m	1,00	3,00	4,27	6,00	7,77	9,70	11,60	13,60	15,60	17,60	19,60	22,00	24,15	26,50

HC801 E10

kg	65280*	21760*	14350	9955	7275	5505	4370	3550	2955	2515	2205	1950	1760	1310
m	1,00	3,00	4,55	6,25	8,05	10,00	11,85	13,85	15,85	17,85	19,85	22,00	24,15	26,50

HC801 E6J6

kg										1715	1510	1370	1245	1135	1045	925	630
m										18,80	20,40	22,05	23,70	25,40	27,20	29,00	31,00

HC801 E8J4

kg													960	860	780	715	665	555
m													22,20	23,90	25,65	27,40	29,20	31,10

*) Theoretical lifting capacity

- CE**
- NO CE**
- MANUAL**
- RADIO**

HC 801



- EES** Extra Extension Speed
- SDS** Smooth Descent System
- TCU** Total Control Unit
- LCS** Lift Control System
- LAS** Liftrod Articulating System

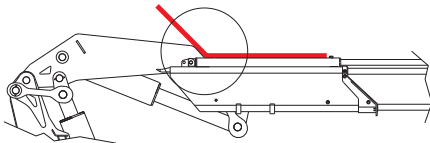

Second boom with negative angle in order to simplify operations in difficult access conditions

MODELS	LIFTING MOMENT	MAX VERTICAL REACH (HYDR)	SLEWING ANGLE	SLEWING TIME	MAX WORKING HEEL	WORKING PRESSURE	CRANE WEIGHT WITHOUT STABILIZERS	OIL TANK CAPACITY	OIL FLOW	DIMENSIONS
	tm	m	°	s/180°	°	bar	kg	l	l/min	
HC801 E2	74,0	12,1	Endless	40	4	315	6350	280	100	2530x2450x1610
HC801 E4	-	16,0	Endless	40	4	315	7000	280	100	2530x2450x1610
HC801 E6	-	20,2	Endless	50	4	315	7600	280	100	2530x2450x1770
HC801 E8	-	24,1	Endless	50	4	315	8150	280	100	2530x2505x1795
HC801 E10	-	28,7	Endless	60	4	315	8550	280	100	2530x2635x1795
HC801 E6J6	-	33,6	Endless	60	4	315	9100	280	100	2530x2800x1900
HC801 E8J4	-	34,0	Endless	60	4	315	9000	280	100	2545x2875x1900

HC 951

EES

LCS

LAS



HC951 E4

kg	81330*	27060	18400	13530	10700	8660	7220
m	1,00	2,90	4,42	5,94	7,44	9,14	10,32

HC951 E5

kg	79580*	25690	17300	12900	10100	8140	6770	5760
m	1,00	2,90	4,60	6,10	7,70	9,40	11,15	13,1

HC951 E6

kg	79360*	26340	17290	12600	9910	7940	6550	5520	4740
m	1,00	2,90	4,60	6,11	7,61	9,31	11,09	13,0	15,02

HC951 E7

kg	77520*	24950	16150	11900	9260	7400	6090	5130	4390	3820
m	1,00	2,90	4,80	6,30	7,90	9,60	11,4	13,3	15,3	17,45

HC951 E8

kg	77390*	25620	16190	11660	9110	6850	5890	4900	4150	3620	3130
m	1,00	2,90	4,78	6,31	7,81	10,05	11,3	13,20	15,22	17,35	19,63

HC951 E9

kg	76950*	25440	15800	11370	8870	7040	5720	4740	4000	3440	3010	2590
m	1,00	2,90	4,87	6,38	7,90	9,60	11,38	13,30	15,31	17,44	19,36	21,53

HC951

E6J4

kg										3130	2820	2400	1810	1440
m										17,7	19,2	20,8	22,5	24,3

E8J6

kg															1670	1510	1380	1265	1165	960	805
m															22,52	24,02	25,62	27,32	29,12	31,0	32,86

*) Theoretical lifting capacity

CE	<input checked="" type="checkbox"/>
NO CE	<input checked="" type="checkbox"/>
MANUAL	<input type="checkbox"/>
RADIO	<input checked="" type="checkbox"/>

HC 951



- EES** Extra Extension Speed
- LCS** Proportional Lift Control System
- LAS** Liftrod Articulating System

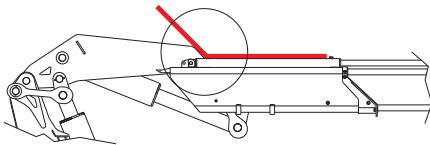



Second boom with negative angle in order to simplify operations in difficult access conditions

MODELS	LIFTING MOMENT	MAX VERTICAL REACH (HYDR)	SLEWING ANGLE	SLEWING TIME	MAX WORKING HEEL	WORKING PRESSURE	CRANE WEIGHT WITHOUT STABILIZERS	OIL TANK CAPACITY	OIL FLOW	DIMENSIONS
	tm	m	°	s/180°	°	bar	kg	l	l/min	
HC951 E4	81,3	15,3	Endless	21	5	345	7000	300	80	2550x2480x1985
HC951 E5	-	17,3	Endless	21	5	345	7420	300	80	2550x2480x1985
HC951 E6	-	19,3	Endless	21	5	345	7750	300	80	2550x2480x1985
HC951 E7	-	21,6	Endless	21	5	345	8060	300	80	2550x2480x1985
HC951 E8	-	23,4	Endless	21	5	345	8220	300	80	2550x2480x1985
HC951 E9	-	25,8	Endless	21	5	345	8400	300	80	2550x2480x1985
HC951 E6J4	-	27,5	Endless	21	5	345	8540	300	80	2550x2720x1995
HC951 E8J6	-	36,1	Endless	21	5	345	9125	300	80	2550x2800x1995

HC 1151



HC1151 E4									
kg	93440*	22050	16250	12500	10000	8430			
m	1,00	4,20	5,75	7,41	9,18	10,91			

HC1151 E6									
kg	91120*	20900	15200	11700	9400	7800	6600	5660	
m	1,00	4,36	5,90	7,55	9,27	11,1	12,97	15,1	

HC1151 E8										
kg	87690*	19400	14100	10800	8500	7000	5700	4900	4300	3760
m	1,00	4,52	6,10	7,72	9,47	11,22	13,28	15,2	17,15	19,52

HC1151 E10												
kg	86940*	18900	13550	10250	8100	6600	5250	4265	3575	3050	2680	2400
m	1,00	4,60	6,20	7,80	9,55	11,3	13,35	15,3	17,25	19,6	21,7	23,8

HC1151 E8J6															
kg									1840	1670	1530	1340	1050	850	720
m									22,5	23,9	25,5	27,2	29,0	30,9	32,8

*) Theoretical lifting capacity

CE	<input checked="" type="checkbox"/>
NO CE	<input checked="" type="checkbox"/>
MANUAL	<input type="checkbox"/>
RADIO	<input checked="" type="checkbox"/>

HC 1151



- EES** Extra Extension Speed
- LCS** Proportional Lift Control System
- LAS** Liftrod Articulating System

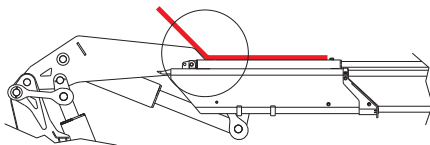

Second boom with negative angle in order to simplify operations in difficult access conditions

MODELS	LIFTING MOMENT	MAX VERTICAL REACH (HYDR)	SLEWING ANGLE	SLEWING TIME	MAX WORKING HEEL	WORKING PRESSURE	CRANE WEIGHT WITH STABILIZERS	OIL TANK CAPACITY	OIL FLOW	DIMENSIONS mm B x h x S
	tm	m	°	s/180°	°	bar	kg	l	l/min	
HC1151 E4	93,4	15,3	Endless	34	5	345	7340	300	120	2540x2560x1900
HC1151 E6	-	19,5	Endless	34	5	345	8000	300	120	2540x2670x1900
HC1151 E8	-	23,9	Endless	34	5	335	8450	300	120	2550x2670x1900
HC1151 E10	-	28,1	Endless	34	5	335	8900	300	120	2550x2790x1900
HC1151 E8J6	-	36,9	Endless	34	5	335	9345	300	120	2550x2670x1920

HC 1651



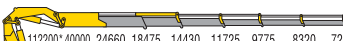

HC1651 E4		kg 118830* 40000 26720 20140 15875 13020 10940
	m	1,00 2,80 4,40 5,90 7,50 9,15 10,9

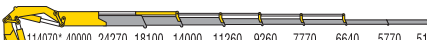
HC1651 E6		kg 112200* 40000 24660 18475 14430 11725 9775 8320 7200
	m	1,00 2,76 4,55 6,00 7,60 9,30 11,1 12,9 14,8

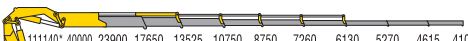
HC1651 E8		kg 114070* 40000 24270 18100 14000 11260 9260 7770 6640 5770 5100
	m	1,00 2,72 4,70 6,15 7,75 9,40 11,15 13,0 15,0 17,0 19,1

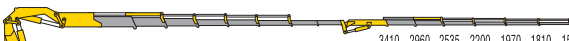
HC1651 E9		kg 111140* 40000 23900 17650 13525 10750 8750 7260 6130 5270 4615 4100
	m	1,00 2,68 4,65 6,15 7,70 9,40 11,15 13,0 15,0 17,0 19,1 21,2

HC1651 E8J6		kg 3410 2960 2535 2200 1970 1810 1520
	m	22,2 23,65 25,1 26,65 28,3 30,05 31,9

HC1651 E8J7		kg 3300 2850 2425 2090 1960 1700 1410 1200
	m	22,2 23,65 25,1 26,65 28,3 30,05 31,9 33,85

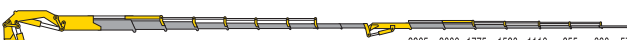
HC1651 E9J7		kg 2265 2000 1775 1520 1110 855 690 575
	m	24,3 25,75 27,2 28,75 30,4 32,15 34,0 36,0

CE	<input checked="" type="checkbox"/>
NO CE	<input checked="" type="checkbox"/>
MANUAL	<input checked="" type="checkbox"/>
RADIO	<input checked="" type="checkbox"/>

*) Theoretical lifting capacity

HC 1651



EES Extra Extension Speed
P-LCS Proportional Lift Control System
LAS Liftrod Articulating System

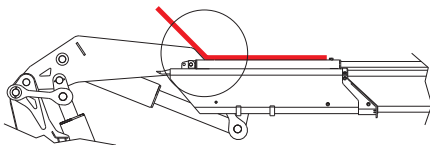

Second boom with negative angle in order to simplify operations in difficult access conditions

MODELS	LIFTING MOMENT	MAX VERTICAL REACH (HYDR)	SLEWING ANGLE	SLEWING TIME	MAX WORKING HEEL	WORKING PRESSURE	CRANE WEIGHT WITH STABILIZERS	OIL TANK CAPACITY	OIL FLOW	DIMENSIONS
	tm	m	°	s/180°	°	bar	kg	l	l/min	
HC1651 E4	119	15,5	Endless	70	5	345	13040	640	100+50	2550x2595x3190
HC1651 E6	-	19,3	Endless	70	5	345	14220	640	100+50	2550x2595x3190
HC1651 E8	-	23,0	Endless	70	5	345	14880	640	100+50	2550x2595x3190
HC1651 E9	-	25,1	Endless	70	5	345	15180	640	100+50	2550x2595x3190
HC1651 E8J6	-	36,5	Endless	70	5	345	16215	640	100+50	2550x2886x3351
HC1651 E8J7	-	37,6	Endless	70	5	345	16480	640	100+50	2550x2886x3351
HC1651 E9J7	-	39,8	Endless	70	5	345	16780	640	100+50	2550x2886x3351



HV

HV 27

HV 47

HV 77

HV 107

HV 147

HV 197

HV 227

When looking for a compact articulated crane, simple to operate, with high lifting capacity, HV line is the perfect solution for cost and performance

HV 27



HV27 E2

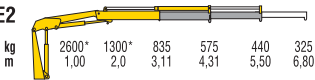

HV27 E3

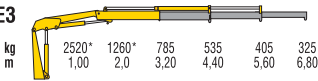

*) Theoretical lifting capacity

CE	<input checked="" type="checkbox"/>
NO CE	<input checked="" type="checkbox"/>
MANUAL	<input checked="" type="checkbox"/>
RADIO	<input type="checkbox"/>

MODELS	LIFTING MOMENT	MAX VERTICAL REACH (HYDR)	SLEWING ANGLE	SLEWING TIME	MAX WORKING HEEL	WORKING PRESSURE	CRANE WEIGHT WITHOUT STABILIZERS	OIL TANK CAPACITY	OIL FLOW	DIMENSIONS
	tm	m	°	s/180°	°	bar	kg	l	l/min	mm B x h x S
HV27 E2	2,60	7,93	370	13	4	205	375	17,5	10	1900x1635x352
HV27 E3	-	9,19	370	13	4	205	405	17,5	10	1900x1635x352

HV 47



HV47 E1

kg	4300*	2150*	1325	965	705
m	1,00	2,00	3,23	4,44	5,75

HV47 E2

kg	4170*	2085*	1250	900	705	540
m	1,00	2,00	3,33	4,54	5,75	7,06

HV47 E3

kg	4060*	2030*	1180	845	650	540	425
m	1,00	2,00	3,43	4,64	5,85	7,06	8,37

*) Theoretical lifting capacity

CE	<input checked="" type="checkbox"/>
NO CE	<input checked="" type="checkbox"/>
MANUAL	<input checked="" type="checkbox"/>
RADIO	<input type="checkbox"/>

MODELS	LIFTING MOMENT	MAX VERTICAL REACH (HYDR)	SLEWING ANGLE	SLEWING TIME	MAX WORKING HEEL	WORKING PRESSURE	CRANE WEIGHT WITHOUT STABILIZERS	OIL TANK CAPACITY	OIL FLOW	DIMENSIONS
	tm	m	°	s/180°	°	bar	kg	l	l/min	
HV47 E1	4,30	7,22	380	16	4	270	565	48	14	2155x1955x420
HV47 E2	-	8,51	380	16	4	270	615	48	14	2155x1955x420
HV47 E3	-	9,81	380	16	4	270	660	48	14	2155x1955x420

HV 77



HV77 E1

kg	7550*	3775*	2195	1560	1140
m	1,00	2,00	3,43	4,79	6,23

HV77 E2

kg	7340*	3670*	2085	1470	1140	870
m	1,00	2,00	3,51	4,87	6,23	7,66

HV77 E3

kg	7130*	3565*	1990	1405	1080	870	665
m	1,00	2,00	3,58	4,94	6,30	7,66	9,05

*) Theoretical lifting capacity

CE	<input checked="" type="checkbox"/>
NO CE	<input checked="" type="checkbox"/>
MANUAL	<input checked="" type="checkbox"/>
RADIO	<input type="checkbox"/>

MODELS	LIFTING MOMENT	MAX VERTICAL REACH (HYDR)	SLEWING ANGLE	SLEWING TIME	MAX WORKING HEEL	WORKING PRESSURE	CRANE WEIGHT WITHOUT STABILIZERS	OIL TANK CAPACITY	OIL FLOW	DIMENSIONS
	tm	m	°	s/180°	°	bar	kg	l	l/min	mm B x h x S
HV77 E1	7,55	7,81	380	16	4	255	770	48	16	2320x2030x565
HV77 E2	-	9,22	380	16	4	255	830	48	16	2320x2030x565
HV77 E3	-	10,64	380	16	4	255	890	48	16	2320x2030x565

HV 107



HV107 E1

kg	9560*	3915**	2425	1720	1230
m	1,00	2,42	3,91	5,56	7,35

HV107 E2

kg	9180*	3770**	2300	1605	1230	895
m	1,00	2,42	3,99	5,64	7,34	9,22

HV107 E3

kg	8880*	3670**	2170	1485	1120	895	675
m	1,00	2,42	4,08	5,73	7,43	9,22	11,17

*) Theoretical lifting capacity
 **) Fixed hook capacity

CE	<input checked="" type="checkbox"/>
NO CE	<input checked="" type="checkbox"/>
MANUAL	<input checked="" type="checkbox"/>
RADIO	<input type="checkbox"/>

MODELS	LIFTING MOMENT	MAX VERTICAL REACH (HYDR)	SLEWING ANGLE	SLEWING TIME	MAX WORKING HEEL	WORKING PRESSURE	CRANE WEIGHT WITHOUT STABILIZERS	OIL TANK CAPACITY	OIL FLOW	DIMENSIONS
	tm	m	°	s/180°	°	bar	kg	l	l/min	
HV107 E1	9,56	9,30	380	15	4	275	1030	100	25	2490X2320X635
HV107 E2	-	11,08	380	15	4	275	1130	100	25	2490X2320X635
HV107 E3	-	12,95	380	15	4	275	1220	100	25	2490X2320X690

HV 147



HV147 E1

kg	13870*	5820**	3455	2485	1815	
m	1,00	2,34	3,93	5,58	7,36	

HV147 E2

kg	13360*	5655**	3295	2355	1815	1380
m	1,00	2,34	4,01	5,66	7,36	9,23

HV147 E3

kg	12930*	5525**	3160	2250	1715	1380	1015
m	1,00	2,34	4,08	5,73	7,43	9,23	11,14

*) Theoretical lifting capacity

**) Fixed hook capacity

CE	<input checked="" type="checkbox"/>
NO CE	<input checked="" type="checkbox"/>
MANUAL	<input checked="" type="checkbox"/>
RADIO	<input type="checkbox"/>

MODELS	LIFTING MOMENT	MAX VERTICAL REACH (HYDR)	SLEWING ANGLE	SLEWING TIME	MAX WORKING HEEL	WORKING PRESSURE	CRANE WEIGHT WITHOUT STABILIZERS	OIL TANK CAPACITY	OIL FLOW	DIMENSIONS
	tm	m	°	s/180°	°	bar	kg	l	l/min	mm B x h x S
HV147 E1	13,9	9,54	380	15	4	285	1375	100	25	2500X2455X820
HV147 E2	-	11,3	380	15	4	285	1490	100	25	2500X2455X820
HV147 E3	-	13,1	380	15	4	285	1595	100	25	2500X2455X820

HV 197



HV197 E1

kg	19110*	7965**	4715	3395	2510
m	1,00	2,33	3,98	5,63	7,41

HV197 E2

kg	18600*	7765**	4520	3240	2510	1915
m	1,00	2,33	4,06	5,71	7,41	9,28

HV197 E3

kg	17940*	7610**	4345	3100	2380	1915	1510
m	1,00	2,33	4,13	5,78	7,48	9,28	11,15

*) Theoretical lifting capacity

**) Fixed hook capacity

CE	<input checked="" type="checkbox"/>
NO CE	<input checked="" type="checkbox"/>
MANUAL	<input checked="" type="checkbox"/>
RADIO	<input type="checkbox"/>

MODELS	LIFTING MOMENT	MAX VERTICAL REACH (HYDR)	SLEWING ANGLE	SLEWING TIME	MAX WORKING HEEL	WORKING PRESSURE	CRANE WEIGHT WITHOUT STABILIZERS	OIL TANK CAPACITY	OIL FLOW	DIMENSIONS
	tm	m	°	s/180°	°	bar	kg	l	l/min	mm B x h x S
HV197 E1	19,1	9,35	380	15	4	295	1715	150	40	2500X2475X920
HV197 E2	-	11,0	380	15	4	295	1850	150	40	2500X2475X920
HV197 E3	-	12,8	380	15	4	295	1975	150	40	2500X2475X920

HV 227

LCS



HV227 E1

kg	20520*	8490**	5035	3645	2710
m	1,00	2,33	3,98	5,63	7,41

HV227 E2

kg	20080*	8460**	4835	3485	2710	2075
m	1,00	2,33	4,06	5,71	7,41	9,28

HV227 E3

kg	19370*	8315**	4670	3330	2570	2075	1640
m	1,00	2,33	4,13	5,78	7,48	9,28	11,15

*) Theoretical lifting capacity

**) Fixed hook capacity

CE	<input checked="" type="checkbox"/>
NO CE	<input checked="" type="checkbox"/>
MANUAL	<input checked="" type="checkbox"/>
RADIO	<input type="checkbox"/>

MODELS	LIFTING MOMENT	MAX VERTICAL REACH (HYDR)	SLEWING ANGLE	SLEWING TIME	MAX WORKING HEEL	WORKING PRESSURE	CRANE WEIGHT WITHOUT STABILIZERS	OIL TANK CAPACITY	OIL FLOW	DIMENSIONS
	tm	m	°	s/180°	°	bar	kg	l	l/min	mm B x h x S
HV227 E1	20,5	9,35	380	15	4	315	1745	150	40	2500X2475X945
HV227 E2	-	11,05	380	15	4	315	1880	150	40	2500X2475X945
HV227 E3	-	12,84	380	15	4	315	2005	150	40	2500X2475X945





MAN BASKET

HA50 MB

HA70 MB

MAN BASKET



Thanks to the special "self-aligning" balancing system, the position of the basket is always horizontal without any intervention from the user.

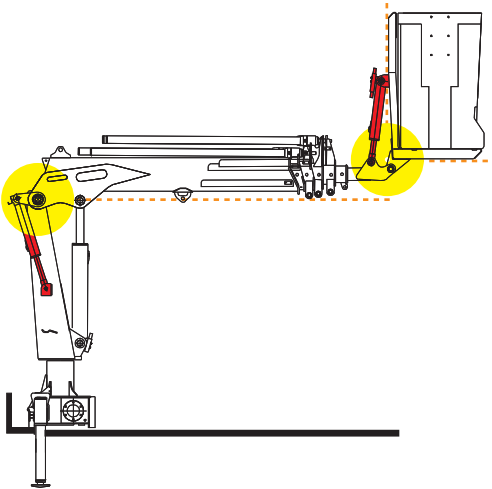

MAN BASKET

CE	<input type="checkbox"/>
NO CE	<input checked="" type="checkbox"/>
MANUAL	<input checked="" type="checkbox"/>
RADIO	<input checked="" type="checkbox"/>

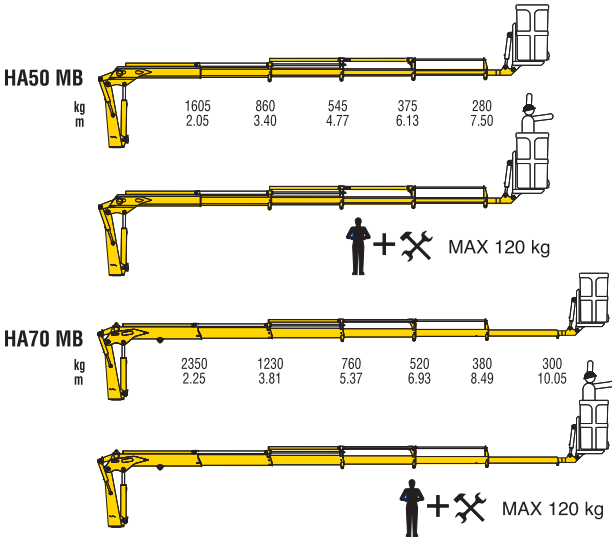

MODELS	LIFTING MOMENT	MAX VERTICAL REACH (HYDR)	SLEWING ANGLE	SLEWING TIME	MAX WORKING HEEL	WORKING PRESSURE	CRANE WEIGHT (STAB. STANDARD)	OIL TANK CAPACITY	OIL FLOW	DIMENSIONS
	tm	m	°	s/180°	°	bar	kg	l	l/min	mm B x h x S
HA50 MB	3,29	13,30	380	-	4	220	940	35	15	3305x1940x850
HA70 MB	5,29	16,00	387	-	4	220	1260	35	18	3765x2080x850



FFB

HB 10S FFB

HB 11 FFB

HB 16 FFB

HB 50S FFB

HB 50 FFB

SPECIALIZED CRANES FOR AGRICULTURAL TRACTORS

Uniquely engineered to support advanced applications in the agricultural industry, the FFB line boosts the productivity and efficiency while enhancing the speed and safety of harvesting activities.



Easy and Safe



Easy to use and maintain

All the greasing point are in a easy to access position.



Cable controls

Connection by cable controls allow an easy installation and a higher safety for the driver.

4 functions control valve by Walvoil



7 functions control valve by Hidrocontrol



Strong and reliable



Structural design in accordance with: EN12999



Quality ISO9001: 2008 certified

Production from the raw metal to the crane ready to be installed is controlled by quality procedures certified by Lloyd's register according to ISO9001.

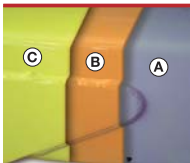

Long life painting

Painting process is made to allow the best quality possible and ensure a long crane life in all the applications and environments.

- A - Iron grid sandblasting
- B - Cathodic electrodeposition paint
- C - Yellow polyester powder paint



Hexagonal boom

The use of this technology brings superior performance, reduced maintenance, and less adjustment.

Strong and reliable

Rack and Pinion heavy duty slewing

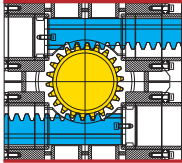

Double rack and pinion heavy duty slewing

The use of two racks spread the force across twice as many teeth on the pinion. Slewing has more strength for difficult situations.

Internal extension cylinder

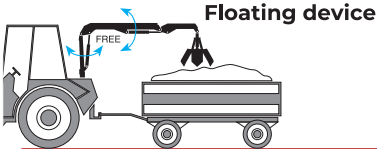
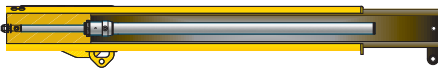

Full packages



3 Jaws grab

Self weight: 35 kg
Capacity: 50 dm³



4 jaws grab

Self weight: 75 kg
Capacity: 100 dm³



box grab

Special attachment for bulk material



Oil tank

Steel oil tank made to be installed on the back of the tractor including oil filter and level indicators.



FFB



HB10S FFB

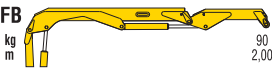

HB11 FFB

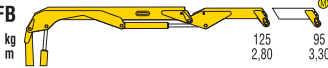

HB16 FFB

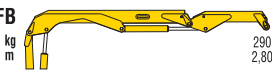

HB50S FFB

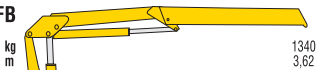

HB50 FFB

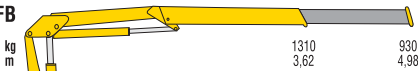

Ⓜ Manual extension (weight kg 10)

CE	<input type="checkbox"/>
NO CE	<input checked="" type="checkbox"/>
MANUAL	<input checked="" type="checkbox"/>
RADIO	<input type="checkbox"/>

MODELS	LIFTING MOMENT	MAX VERTICAL REACH (HYDR)	SLEWING ANGLE	SLEWING TIME	MAX WORKING HEEL	WORKING PRESSURE	CRANE WEIGHT WITHOUT MANUAL EXTENSION	OIL TANK CAPACITY	OIL FLOW	RACOMMENDED TRACTOR
	tm	m	°	s/180°	°	bar	kg	l	l/min	hp
HB10S FFB	-	3,1	330	45	10	70	148	25	12	-
HB11 FFB	0,5	3,7	330	4	10	90	166	25	12	25 - 65
HB16 FFB	1,0	3,7	330	4	10	160	166	46	12	25 - 65
HB50S FFB	-	5,7	380	36	4	275	625	35	15	80
HB50 FFB	4,8	6,7	330	10	4	275	675	35	15	-



HZ

HZR L

HZR Z

HZT L

HZT Z

HZR

SPECIALIZED CRANES FOR RECYCLING APPLICATIONS

Designed specifically to meet the needs of recycling applications, the HZR is available in foldable (Z) and non-foldable (L) versions.

With a wide range of models and versions, these cranes are the perfect solution for scrap and container handling from 8 to 25 tm. Offering high-speed performance, it's perfect one-stop solution when combined with Hyva hookloaders and attachments.

HZT

SPECIALIZED CRANES FOR TIMBER APPLICATION

Designed specifically to meet the needs of timber applications, the HZT offers exceptional performance, high flexibility and a wide choice of accessories. With a wide range of models and versions, these cranes are the perfect solution for wood transport from 4 to 27 tm.

Foldable (Z) and non-foldable (L) versions are available.



HZR ZO

HZR080 ZO

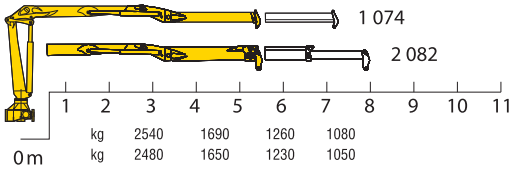

CE	<input checked="" type="checkbox"/>
NO CE	<input checked="" type="checkbox"/>
MANUAL	<input checked="" type="checkbox"/>
RADIO	<input checked="" type="checkbox"/>

HZR100 ZO

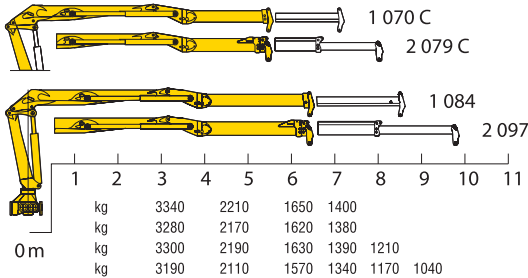

HZR120 ZO

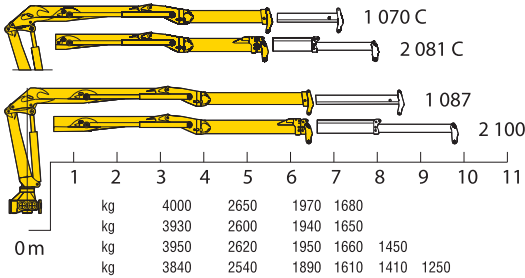

HZR150 ZO

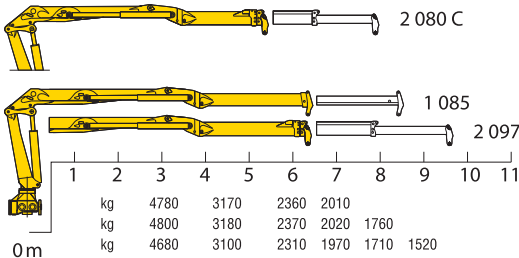

HZR Z0

HZR170 Z0

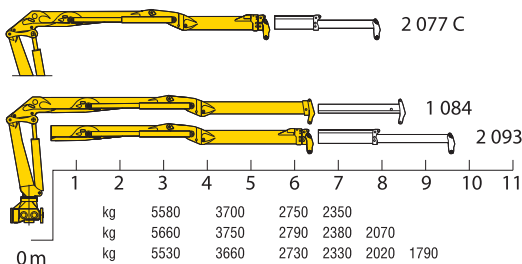

HZR210 Z0

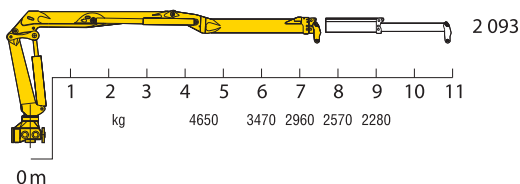

Models	lifting moment (kNm)	Slewing torque (kNm)	Slewing angle (°)	Slewing speed (rpm)	Working pressure (MPa)	Oil flow (l/min)	Crane weight (kg)
HZR080 Z0							
1 074	78	18	420	6	260	70 2x60	1730
2 082	76	18	420	6	260	70 2x60	1820
HZR100 Z0							
1 070 C	100	22	435	6	240	80 2x70	2250
2 079 C	99	22	435	6	240	80 2x70	2310
1 084	99	22	435	6	240	80 2x70	2300
2 097	96	22	435	6	240	80 2x70	2370
HZR120 Z0							
1 070 C	120	25	435	6	240	80 2x70	2360
2 081 C	118	25	435	6	240	80 2x70	2450
1 087	119	25	435	6	240	80 2x70	2440
2 100	116	25	435	6	240	80 2x70	2560
HZR150 Z0							
2 080 C	144	30	435	6	245	90 2x80	2550
1 085	144	30	435	6	245	90 2x80	2540
2 097	141	30	435	6	245	90 2x80	2660
HZR170 Z0							
2 077 C	168	35	435	6	250	2x90	3040
1 084	170	35	435	6	250	2x90	3030
2 093	166	35	435	6	250	2x90	3150
HZR210 Z0							
2 093	210	38	390	6	220	2x90	3210

HZR Z1



HZR100 Z1

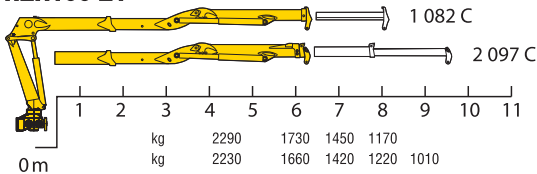

CE	<input checked="" type="checkbox"/>
NO CE	<input checked="" type="checkbox"/>
MANUAL	<input checked="" type="checkbox"/>
RADIO	<input checked="" type="checkbox"/>

HZR120 Z1

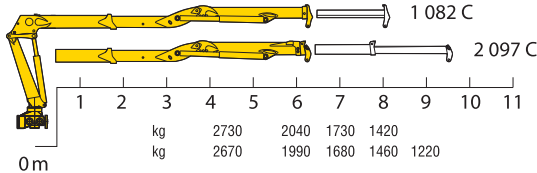

HZR150 Z1

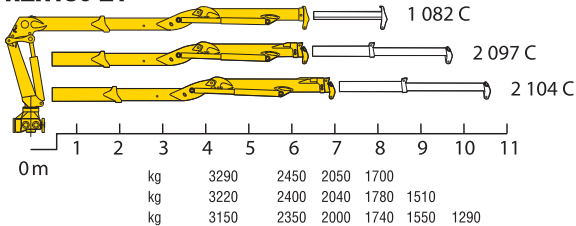

HZR Z1

HZR180 Z1

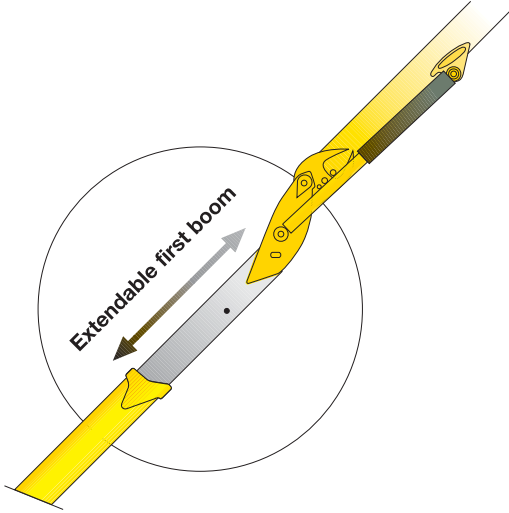
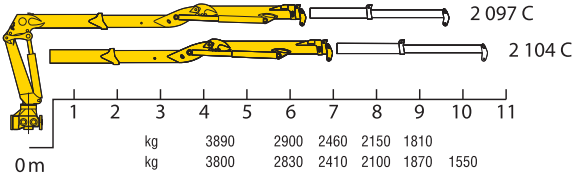

Models	lifting moment (kNm)	Stewing torque (kNm)	Stewing angle (°)	Stewing speed (rpm)	Working pressure (MPa)	Oil flow (l/min)	Crane weight (kg)
HZR100 Z1							
1 082 C	104	28	435	6	235	80 2x70	2350
2 097 C	100	28	435	6	235	80 2x70	2440
HZR120 Z1							
1 082 C	123	30	435	6	255	80 2x70	2390
2 097 C	120	30	435	6	255	80 2x70	2480
HZR150 Z1							
1 082 C	148	32	435	6	245	90 2x80	2690
2 097 C	145	32	435	6	245	90 2x80	2780
2 104 C	142	32	435	6	245	90 2x80	2950
HZR180 Z1							
2 097 C	175	34	435	6	265	90 2x90	2860
2 104 C	171	34	435	6	265	90 2x90	3030





HZR LO

HZR080 LO

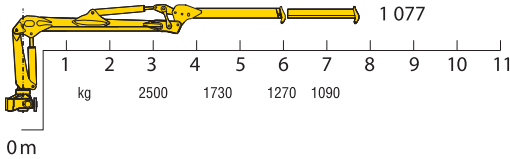

CE	<input checked="" type="checkbox"/>
NO CE	<input checked="" type="checkbox"/>
MANUAL	<input checked="" type="checkbox"/>
RADIO	<input checked="" type="checkbox"/>

HZR100 LO

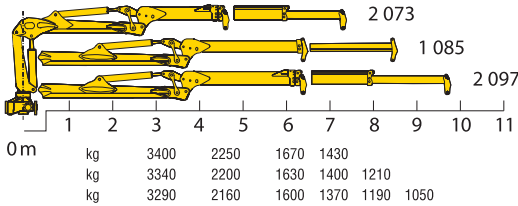

HZR120 LO

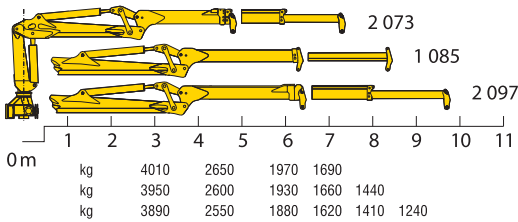

HZR140 LO

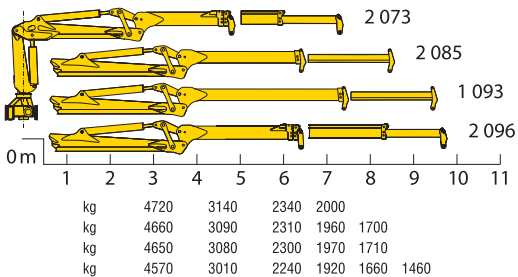





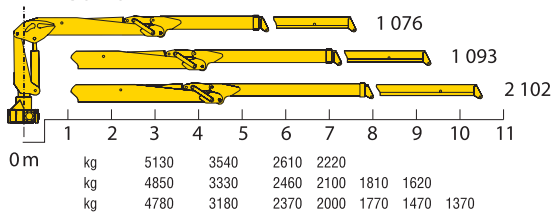

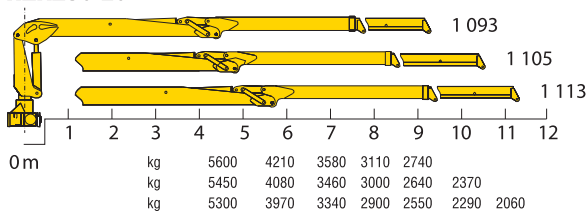

HZR LO

HZR160 LO



HZR250 LO



	 lifting moment	 Slewing torque	 Slewing angle	 Slewing speed	 Working pressure	 Oil flow	 Crane weight
Models	(kNm)	(kNm)	(°)	(rpm)	(MPa)	(l/min)	kg
HZR080 LO							
1 077	79	18	430	5	230	70	1550
HZR100 LO							
2 073	102	22	435	5	220	80 2x70	1950
1 085	100	22	435	5	220	80 2x70	2000
2 097	96	22	435	5	220	80 2x70	2090
HZR120 LO							
2 073	122	25	435	5	240	80 2x70	2080
1 085	120	25	435	5	240	80 2x70	2150
2 097	116	25	435	5	240	80 2x70	2220
HZR140 LO							
2 073	142	30	435	5	240	90 2x80	2430
2 085	140	30	435	5	240	90 2x80	2460
1 093	139	30	435	5	240	90 2x80	2520
2 096	135	30	435	5	240	90 2x80	2600
HZR160 LO							
1 076	161	35	435	5	230	2x90	2580
1 093	151	35	435	5	230	2x90	2800
2 102	136	35	435	5	230	2x90	2860
HZR250 LO							
1 093	256	38	435	5	230	2x90	3120
1 105	244	38	435	5	230	2x90	3280
1 113	241	38	435	5	230	2x90	3370

HZR L1



HZR080 L1



CE	<input checked="" type="checkbox"/>
NO CE	<input checked="" type="checkbox"/>
MANUAL	<input checked="" type="checkbox"/>
RADIO	<input checked="" type="checkbox"/>

HZR100 L1

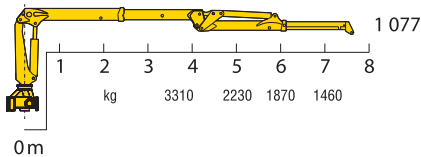

HZR120 L1

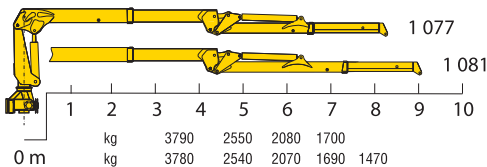

HZR L1

HZR150 L1

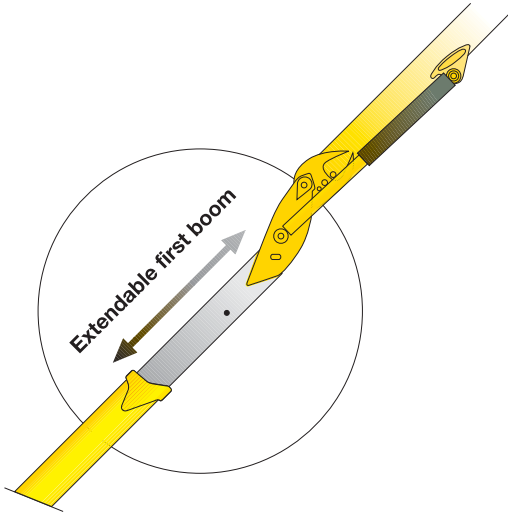
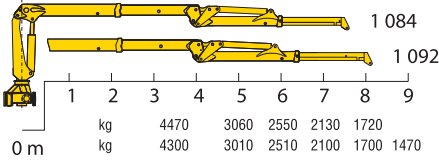

Models	lifting moment (kNm)	Slewing torque (kNm)	Slewing angle (°)	Slewing speed (rpm)	Working pressure (MPa)	Oil flow (l/min)	Crane weight (kg)
HZR080 L1							
1 068	75	18	430	5	220	70	1800
HZR100 L1							
1 077	115	22	435	5	240	80 2x70	2420
HZR120 L1							
1 077	132	25	435	5	250	80 2x70	2480
1 081	132	25	435	5	250	80 2x70	2520
HZR150 L1							
1 084	156	25	435	5	250	90 2x80	2980
1 092	155	25	435	5	250	90 2x80	3130





HZT LO

HZT080 LO

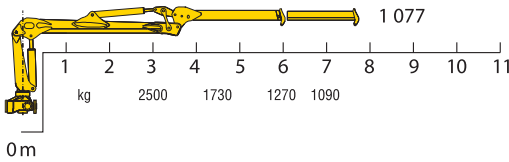

CE	<input checked="" type="checkbox"/>
NO CE	<input checked="" type="checkbox"/>
MANUAL	<input checked="" type="checkbox"/>
RADIO	<input checked="" type="checkbox"/>

HZT100 LO

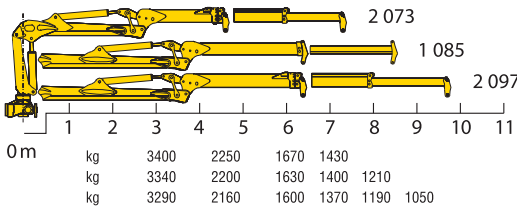

HZT120 LO

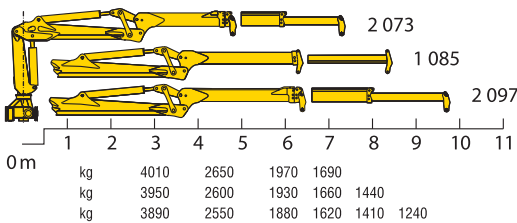

HZT140 LO

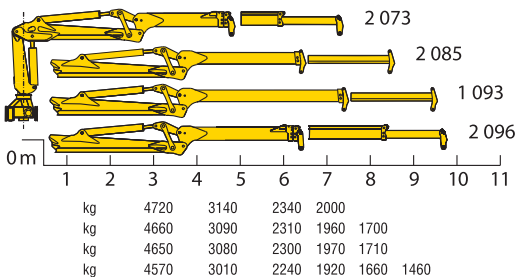

HZT LO

HZT160 LO

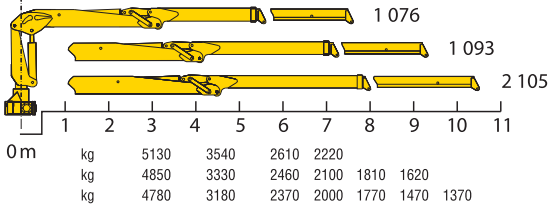

HZT250 LO

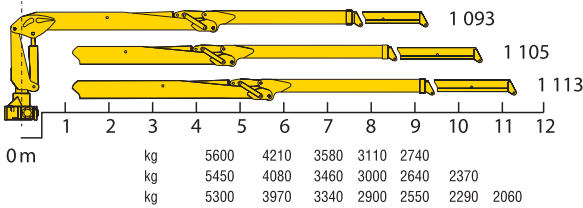

Models	(kNm)	(kNm)	(°)	(rpm)	(MPa)	(l/min)	kg
HZT080 LO							
1 077	79	18	430	5	230	70	1550
HZT100 LO							
2 073	102	22	435	5	220	80 2x70	1950
1 085	100	22	435	5	220	80 2x70	2000
2 097	96	22	435	5	220	80 2x70	2090
HZT120 LO							
2 073	122	25	435	5	240	80 2x70	2080
1 085	120	25	435	5	240	80 2x70	2150
2 097	116	25	435	5	240	80 2x70	2220
HZT140 LO							
2 073	142	30	435	5	240	90 2x80	2430
2 085	140	30	435	5	240	90 2x80	2460
1 093	139	30	435	5	240	90 2x80	2520
2 096	135	30	435	5	240	90 2x80	2600
HZT160 LO							
1 076	161	35	435	5	230	2x90	2580
1 093	151	35	435	5	230	2x90	2800
2 105	136	35	435	5	230	2x90	2860
HZT250 LO							
1 093	256	38	435	5	230	2x90	3120
1 105	244	38	435	5	230	2x90	3280
1 113	241	38	435	5	230	2x90	3370





HZT Z0

HZT040 Z0

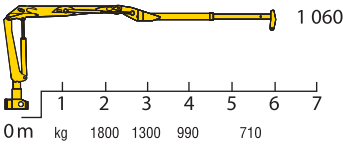

CE	<input checked="" type="checkbox"/>
NO CE	<input checked="" type="checkbox"/>
MANUAL	<input checked="" type="checkbox"/>
RADIO	<input checked="" type="checkbox"/>

HZT080 Z0

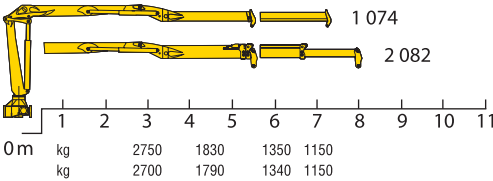

HZT110 Z0

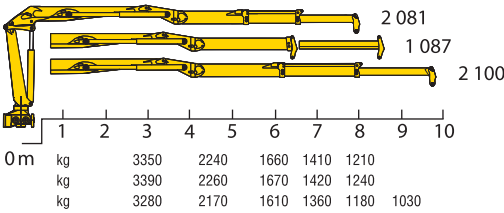

HZT130 Z0

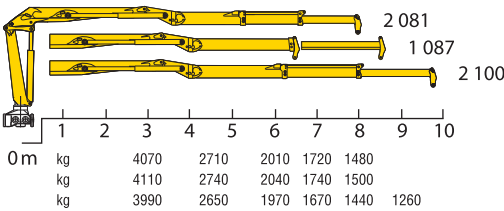

HZT150 Z0

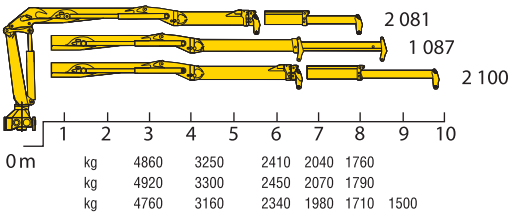

HZT Z0



HZT180 Z0

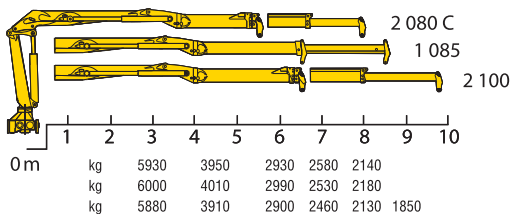

CE	<input checked="" type="checkbox"/>
NO CE	<input checked="" type="checkbox"/>
MANUAL	<input checked="" type="checkbox"/>
RADIO	<input checked="" type="checkbox"/>

HZT210 Z0

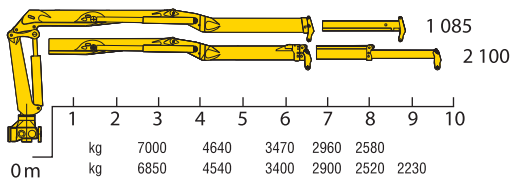



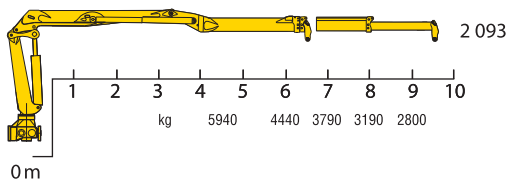



HZT270 Z0



HZT 20



Models	 Lifting moment (kNm)	 Slewing torque (kNm)	 Slewing angle (°)	 Slewing speed (rpm)	 Working pressure (MPa)	 Oil flow (l/min)	 Crane weight (kg)
HZT040 Z0							
1 060	39	11	400	6	210	30	950
HZT080 Z0							
1 074	83	18	425	6	245	70 2x60	1800
2 082	81	18	425	6	245	70 2x60	1940
HZT110 Z0							
2 081	101	28	435	6	240	70 2x60	2020
1 087	102	28	435	6	240	70 2x60	2040
2 100	99	28	435	6	240	70 2x60	2100
HZT130 Z0							
2 081	122	30	435	6	260	80 2x70	2310
1 087	124	30	435	6	260	80 2x70	2300
2 100	120	30	435	6	260	80 2x70	2370
HZT150 Z0							
2 081	146	33	435	6	260	90 2x80	2450
1 087	148	33	435	6	260	90 2x80	2540
2 100	143	33	435	6	260	90 2x80	2560
HZT180 Z0							
2 080C	178	35	435	6	250	90 2x80	2550
1 085	180	35	435	6	250	90 2x80	2540
2 100	175	35	435	6	250	90 2x80	2680
HZT210 Z0							
2 085	210	38	435	5	260	2x90	3030
2 100	206	38	435	5	260	2x90	3150
HZT270 Z0							
2 093	267	42	ENDLESS	5	230	2x100	3210





KENNIS

CRANES BY **HYVA**[®]

13 - RL

14 - R

16 - R

R - 24

R - 30

R - 40

The Kenniss Concept - Maximize The Haulage Payload And Increase Your Productivity.

Fast Operation

Longer Useful Life

Efficient, Simpler & Safer For Users.

Improved Driving Condition

Maximum Payload



HIGH LIFTING CAPACITY AND LOW TARE

The complete Kennis Rolloader concept is the combination of a light crane, light attachment and equally important a light trailer. Kennis Rolloader Cranes are made to perform many cycles at high speed and with exceptional precision. With a lightweight, compact design and a short boom, Kennis cranes can do the same heavy job with a lower load moment (capacity) than a heavy rear mounted crane which will require a long boom. The steel structures of crane and crane equipment have been engineered to perform and endure tough heavy duty load cycles making the crane fast, extremely robust and durable while still very safe to operate.

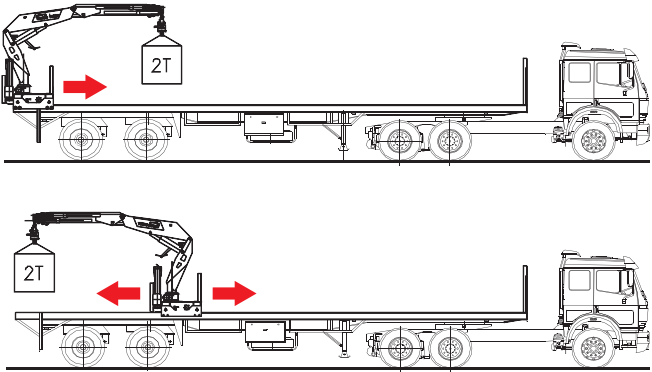

UNRESTRICTED VIEW FROM ITS ERGONOMIC CONTROL

- Better visibility so as to view loading and unloading operations.
- Simple, safe intuitive control.
- Precise and advanced top seat control with levers or four-axis joystick control and foot pedals.
- Ergonomically designed topseat and crane control joysticks improves comfort leading to efficiency, and also increases safety.

RADIO REMOTE CONTROL



Multifunction radio remote control allows the operator to move 2-3-4 or more functions of the crane simultaneously, and to move freely around the trailer and keep control of the load position.

ENVIRONMENTALLY FRIENDLY

- Lower total tare weight so maximum payload is transported.
- Self-propelled crane with its own high performance fuel efficient power unit.
- Variable displacement pump using optimum power resulting in less fuel consumption.



EFFICIENCY

- Faster loading cycle speeds.
- Load/ Unload independently without the use of any other handling equipment on site.
- The crane operation is closer to the load with a shorter boom maximizing the load capacity.
- Self-propelled powered base eliminates the necessity of moving your truck while loading, saving valuable time.
- A precise control of the crane's movement and for accurate placing of the load.
- Easily offload the crane from the trailer.

LONGER USEFUL LIFE

A Kennis crane mounted on the trailer outlasts the useful life far longer than the tractor head truck. Different fleet of tractor heads can also be used for multiple other applications making the operations more flexible as it does not need to have specially fitted hydraulic kits to power the crane.

- Continuous slewing
- Hexagonal boom sections
- Twin high performance lift cylinders

E-Power helps to meet increasingly demanding environmental regulations, with direct tax benefits for the customers in certain countries.



BATTERY PACK AND MOTOR

Electric motors used, feature Kennis integrated electric motors (IEM) and batteries with a new generation of power semiconductors, to achieve best in class efficiency.

CONSTANT TORQUE

Kennis electric motors matches robustness and power by providing the correct torque and constant angular speed to drive the hydraulic pump.

URBAN USE

The electric crane solution is ideal for urban areas and can be operated when the truck engine is switched off.

Kennis e-power cranes lead a pioneering role in the field of electrification and are the latest high-performance innovations, maintaining the best advantages in service and payload.

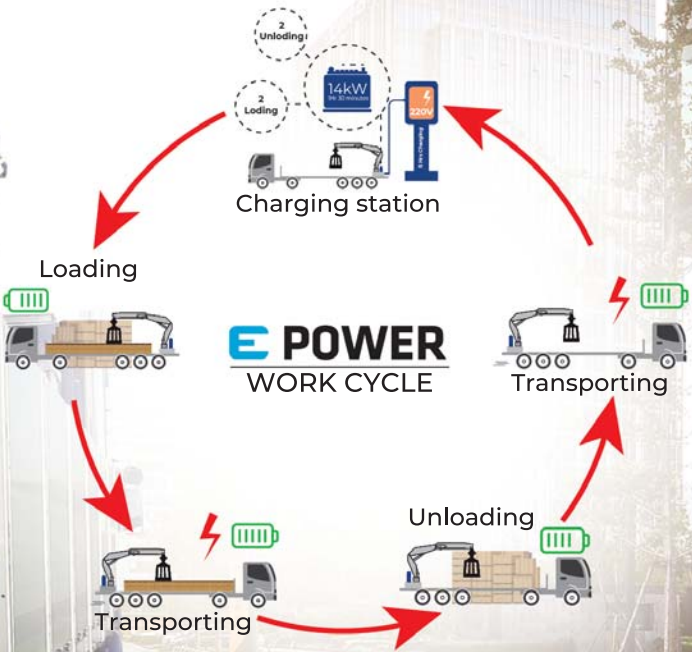

GOING THE EXTRA MILE

Kennis ORRS (On-Road Recharging System). provides energy to recharge service battery from traction battery energy.

FAST RECHARGE

High capacity battery pack, built to deliver maximum energy, without compromising power performances. Battery Management System (BMS) guarantee efficient thermal management, high battery performance and safety.

EFFICIENT ENERGY DISTRIBUTION

High voltage power connection provides for the use of shielded cable with high efficient inner core cross section area.

13-RL

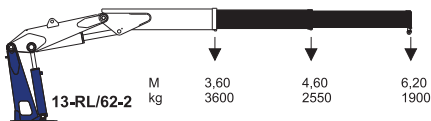

CE	<input checked="" type="checkbox"/>
NO CE	<input type="checkbox"/>
MANUAL	<input checked="" type="checkbox"/>
RADIO	<input checked="" type="checkbox"/>

14-R

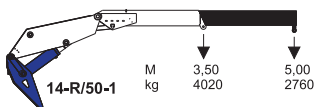

E POWER
Versions available

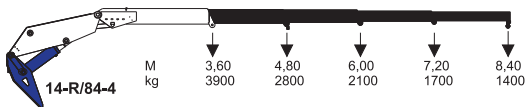
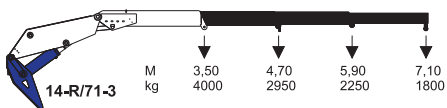
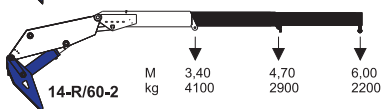

16-R

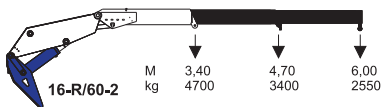

E POWER
Versions available

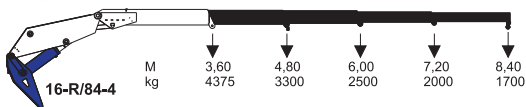
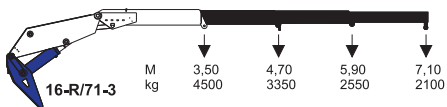

R-24

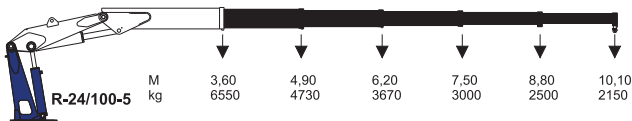
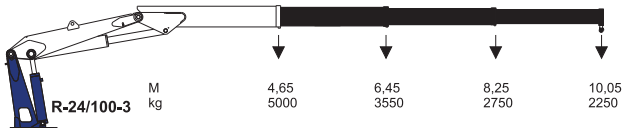
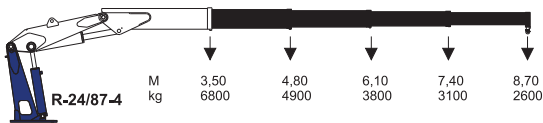
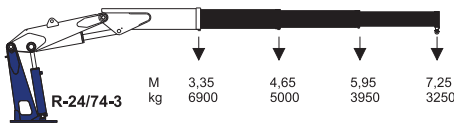

R-30

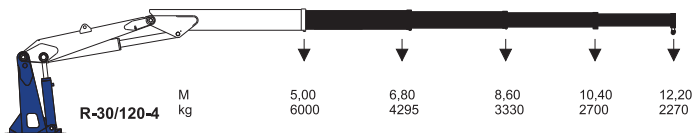
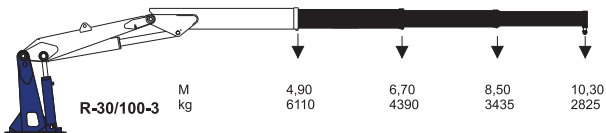
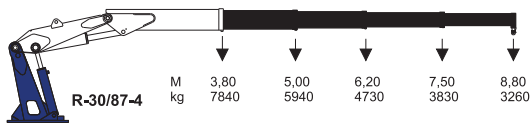
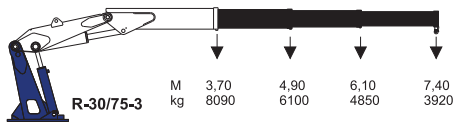

R-40

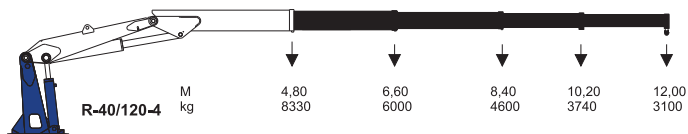
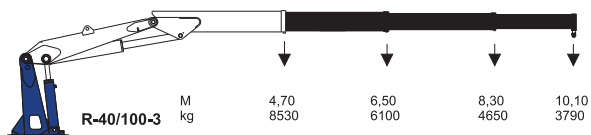
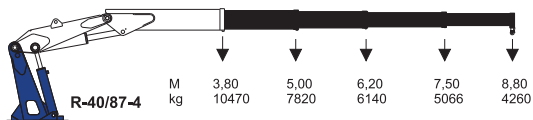
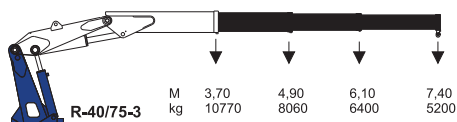

MODELS	LIFTING MOMENT	MAX HYDRAULIC REACH	FOLDABLE	SLEWING ANGLE	HEIGHT	WIDTH	CRANE WEIGHT	LENGTH FOLDED CRANE
	tm	m		°	mm	mm	kg	mm
13-R/62-2	13	6,2	Yes	405	2392	2408	2000	1000
14-R/50-1	14	5,0	Yes	400	2530	2550	2900	1082
14-R/60-2	14	6,0	Yes	400	2440	2550	3000	1082
14-R/71-3	14	7,1	Yes	400	2530	2550	3100	1082
14-R/84-4	14	8,4	Yes	400	2570	2550	3200	1082
16-R/60-2	16	6,0	Yes	400	2440	2550	3100	1082
16-R/71-3	16	7,1	Yes	400	2530	2550	3200	1082
16-R/84-4	16	8,4	Yes	400	2570	2550	3300	1082
R-24/74-3	24	7,3	Yes	'B0	2470	2515	4290	1370
R-24/87-4	24	8,7	Yes	'B0	2550	2515	4450	1370
R-24/100-3	24	10,0	No	'B0	2250	2515	4500	-
R-24/100-5	24	10,1	Yes	'B0	2550	2515	4620	1370
R-30/75-3	30	7,5	Yes	'B0	2470	2515	5400	1590
R-30/87-4	30	8,7	Yes	'B0	2550	2515	5550	1590
R-30/100-3	30	10,3	No	'B0	2300	2515	5750	-
R-30/120-4	30	12,2	No	'B0	2300	2515	6000	-
R-40/75-3	40	8,2	Yes	'B0	2470	2525	6140	1590
R-40/87-4	40	8,8	Yes	'B0	2550	2525	6300	1590
R-40/100-3	40	10,1	No	'B0	2360	2525	6500	-
R-40/120-4	40	12,0	No	'B0	2360	2525	6800	-



Stability control systems (CE) delivered standard with the crane

Models	HS	HM	HML	OPTIONAL HL	HXL	H2XL	H2XL+	H3XL	OPTIONAL H4XL
HA10									
HA14									
HA15	●		✘	✘					
HA21									
HA22	●		✘	✘					
HA27									
HA28	●		✘	✘					
HA33	●		✘	✘					
HA50		●	✘	✘					
HA70			✘	✘	●				
HT92								●	✘
HT112								●	✘
HT130								●	✘
HT162								●	✘
HT212								●	✘
HT240								●	✘
HB 31									
HB38									
HB40									
HB50		●	✘	✘					
HB60			✘	✘	●				
HB70			✘	✘	●				
HB80			✘	✘	●	✘			
HB90								●	✘
HB112								●	✘
HB130								●	✘
HB160								●	✘
HB210								●	✘
HB240								●	✘
HB250					●	✘			
HB280					●	✘			
HC91								●	✘
HC91K								●	✘
HC95								●	✘
HC103								●	✘
HC111								●	✘
HC111K								●	✘

● Manual control ✘ Radio Version

Stability control systems (CE) delivered standard with the crane

Models	HS	HM	HML	OPTIONAL HL	HXL	H2XL	H2XL+	H3XL	OPTIONAL H4XL
HC121								●	✗
HC125								✗	✗
HC131								●	✗
HC131K								●	✗
HC143								●	✗
HC153								✗	✗
HC161								●	✗
HC161K								●	✗
HC173								●	✗
HC183								✗	✗
HC213								●	✗
HC213K								●	✗
HC223								●	✗
HC231								✗	✗
HC235e								✗	✗
HC243								●	✗
HC243K								●	✗
HC245								●	✗
HC261								✗	✗
HC265e								✗	✗
HC291					●	✗			
HC331					●	✗			
HC361					●	✗			
HC501						✗			
HC601e								✗	✗
HC661e								✗	✗
HC801						✗			
HC951							✗		
HC1151							✗		
HC1651							✗		
HV27									
HV47		●							
HV77		●							
HV107		●							
HV147		●							
HV197		●							
HV227		●							

● Manual control ✗ Radio Version

Data, descriptions, and illustrations pertain only and uniquely to models sold at the time of printing of this brochure. After the date of printing, this information is purely indicative and not binding upon HYVA. Future modifications are solely at the discretion of HYVA and are always in compliance with applicable and pertinent safety standards. To obtain updated data, descriptions, and illustrations, contact the manufacturer or your reseller. Cranes manufactured and/or marketed by HYVA, HYVA is not responsible for the special applications depicted. Crane applications and accessories described herein are only examples. Some applications and equipment shown may not be approved for use in CE countries or other areas. It is the installer's responsibility to ensure that the crane is applied correctly, and that its application, installation, and accessories maintain safety and comply with all local laws.

110 countries
+3,500 employees
+30,000 customers
+30 subsidiaries
14 production facilities



Hyva is a leading provider of innovative and highly efficient transport solutions for commercial vehicles used in transport, construction, mining, materials handling and environmental service industries.

Founded in 1979 in the Netherlands, the company has a global presence with 37 fully owned subsidiaries, extraordinary service coverage and 12 manufacturing facilities in Brazil, China, Europe and India.

For more information on Hyva, please visit www.hyva.com

or follow us on:



**Quality and
environmental certified**

Hyva India Pvt. Ltd
EL 215 MIDC Mahape Navi
Mumbai 400 701
India
T: +91 22 6761 8888
E: salesindia@hyva.com
info@hyva.com
www.hyva.com

DEALER STAMP

Data, descriptions, and illustrations pertain only and uniquely to models sold at the time of printing of this brochure. After the date of printing, this information is purely indicative and not binding upon HYVA. Future modifications are solely at the discretion of HYVA and are always in compliance with applicable and pertinent safety standards. To obtain updated data, descriptions, and illustrations, contact the manufacturer or your reseller. Cranes manufactured and/or marketed by HYVA. HYVA is not responsible for the special applications depicted. Crane applications and accessories described herein are only examples. Some applications and equipment shown may not be approved for use in CE countries or other areas. It is the installer's responsibility to ensure that the crane is applied correctly, and that its application, installation, and accessories maintain safety and comply with all local laws.